

CHARTER TOWNSHIP OF
YPSILANTI BOARD OF TRUSTEES

Supervisor

BRENDA L. STUMBO

Clerk

KAREN LOVEJOY ROE

Treasurer

LARRY J. DOE

Trustees

STAN ELDRIDGE

HEATHER JARRELL ROE

MONICA ROSS WILLIAMS

JIMMY WILSON, JR.

December 6, 2016Rev. 12-6-16

Work Session – 6:00 p.m.

Regular Meeting – 7:00 p.m.

**Ypsilanti Township Civic Center
7200 S. Huron River Drive
Ypsilanti, MI 48197**



Charter Township of Ypsilanti

7200 S. HURON RIVER DRIVE • YPSILANTI, MI 48197

SUPERVISOR BRENDA STUMBO • CLERK KAREN LOVEJOY ROE • TREASURER LARRY DOE
TRUSTEES: STAN ELDRIDGE • HEATHER JARRELL ROE • MONICA ROSS WILLIAMS •
JIMMIE WILSON, JR.

WORK SESSION AGENDA CHARTER TOWNSHIP OF YPSILANTI TUESDAY, DECEMBER 6, 2016

6:00PM

**CIVIC CENTER
BOARD ROOM
7200 HURON RIVER DRIVE**

1. AGENDA REVIEW SUPERVISOR STUMBO
2. OTHER DISCUSSION BOARD MEMBERS

REVIEW AGENDA

- A. SUPERVISOR STUMBO WILL REVIEW BOARD MEETING AGENDA

OTHER DISCUSSION

- A. BOARD MEMBERS HAVE THE OPPORTUNITY TO DISCUSS ANY OTHER PERTINENT ISSUES



Charter Township of Ypsilanti

7200 S. HURON RIVER DRIVE • YPSILANTI, MI 48197

SUPERVISOR BRENDA STUMBO • CLERK KAREN LOVEJOY ROE • TREASURER LARRY DOE
TRUSTEES: STAN ELDRIDGE • HEATHER JARRELL ROE • MONICA ROSS WILLIAMS •
JIMMIE WILSON, JR.

REGULAR MEETING AGENDA

TUESDAY, DECEMBER 6, 2016

7:00 P.M.

1. CALL TO ORDER
2. PLEDGE OF ALLEGIANCE AND INVOCATION
3. PUBLIC HEARING
 - A. 7:00PM – RESOLUTION 2016-65, CREATION OF STREETLIGHT SPECIAL ASSESSMENT DISTRICT #208 FOR THE TREMONT SUBDIVISION (PUBLIC HEARING SET AT THE NOVEMBER 1, 2016 REGULAR MEETING)
4. PUBLIC COMMENTS
5. CONSENT AGENDA
 - A. MINUTES OF THE NOVEMBER 15, 2016 WORK SESSION AND REGULAR MEETING
 - B. STATEMENTS AND CHECKS
 1. STATEMENTS AND CHECKS FOR DECEMBER 6, 2016 IN THE AMOUNT OF \$198,254.13
6. ATTORNEY REPORT
 - A. GENERAL LEGAL UPDATE

OLD BUSINESS

1. 2ND READING OF RESOLUTION 2016-58, PROPOSED ORDINANCE 2016-471, AN ORDINANCE AMENDING ORDINANCE 74, THE TOWNSHIP ZONING CODE, REGARDING DEFINITIONS TO UPDATE THE DEFINITION OF FAMILY AND DEFINE THE TERM ROOMING HOUSE (FIRST READING HELD AT THE NOVEMBER 1, 2016 REGULAR MEETING)

NEW BUSINESS

1. BUDGET AMENDMENT #17
2. REQUEST AUTHORIZATION FOR TOWNSHIP ATTORNEY DOUG WINTERS TO ENTER INTO NEGOTIATIONS WITH NEXUS FOR TEMPORARY AND PERMANENT EASEMENT AGREEMENTS

3. REQUEST OF BRIAN MCCLEERY, ASSISTANT ASSESSOR FOR APPROVAL OF THE SALE OF PARCEL # K-11-21-180-005 HUBBARD AVENUE LOTS 122 AND 123 TO ROBERT AND LAVINIA GLODEANU IN THE AMOUNT OF \$1,000.00 WITH THE STIPULATION THAT THE PARCEL WILL BE COMBINED WITH THE PURCHASER'S PROPERTY AND WILL ONLY BE USED FOR THE DEVELOPMENT OF A SINGLE FAMILY, OWNER OCCUPIED RESIDENTIAL PROPERTY
4. REQUEST OF BRIAN MCCLEERY, ASSISTANT ASSESSOR FOR APPROVAL TO ENTER INTO NEGOTIATIONS TO SELL TOWNSHIP OWNED PROPERTY LOCATED ON STATE ST. PARCEL #K-11-13-330-001
5. REQUEST OF DEBBIE AUE, SENIOR ADULT COORDINATOR FOR AUTHORIZATION TO ACCEPT THE HELEN MCCALLA FOUNDATION GRANT IN THE AMOUNT OF \$6,992.97 FOR THE RENOVATION OF AN EXISTING RACQUETBALL COURT INTO A WORKOUT ROOM
6. RESOLUTION 2016-60, ADOPTION OF THE ANNUAL EXEMPTION OPTION AS SET FORTH IN 2011 PUBLIC ACT 152. THE PUBLICLY FUNDED HEALTH INSURANCE CONTRIBUTION ACT
7. RESOLUTION 2016-61, ADOPTION OF REGULAR BOARD MEETING DATES FOR THE 2017 CALENDAR YEAR
8. RESOLUTION 2016-62, ADOPTION OF ROBERT'S RULES OF ORDER FOR 2017
9. RESOLUTION 2016-63, ADOPTION OF DEPOSITORIES FOR 2017
10. RESOLUTION 2016-64, DESIGNATION OF NEWSPAPER OF CIRCULATION
11. 2017 CONTRACTS AND RENEWALS

OTHER BUSINESS

AUTHORIZATIONS AND BIDS

1. REQUEST FOR AUTHORIZATION AND ACCEPTANCE OF THE SALE OF THE FOLLOWING GOLF COURSE EQUIPMENT ON THE MICHIGAN INTERGOVERNMENTAL TRADE NETWORK SURPLUS SALE FOR A TOTAL OF \$16,305.00
 - 2012 TORO GROUNDSMASTER 4100D 4 WHEEL DRIVE BATWING \$ 11,000.00
 - 2006 TORO Z-MASTER \$ 2,500.00
 - 2000 TORO WORKMAN 3200 \$ 1,225.00
 - 1990 TORO SAND PRO 14 W/BLOWER \$ 615.00
 - 2002 TORO DEBRIS BLOWER 600 \$ 965.00

PUBLIC HEARING

- A. Resolution No. 2016-65, Creation of Second Special Assessment Streetlight District for the Tremont Subdivision

RESOLUTION NO. 2016-65

CREATION OF STREETLIGHT SPECIAL ASSESSMENT DISTRICT #208 FOR THE TREMONT SUBDIVISION

WHEREAS, on or about October 6, 2016, the Township Clerk received one petition from the record owners of persons having a vendee's interest as shown by the records in the Washtenaw County Register of Deeds Office or as shown on the tax rolls of the Township, petitioning the Township Board for additional LED street lighting and the conversion of current street lighting to LED for the Tremont Subdivision, consisting of 188 parcels, in Ypsilanti Township and for the creation and establishment of a special assessment district for the purpose of defraying said cost of street lighting by special assessments against the property especially benefited; and

WHEREAS, the Township Clerk requested of Detroit Edison, proposed plans describing the street lighting improvement and the location of said improvements with an estimate of said costs; and

WHEREAS, on October 25, 2016 Lance Alley of Detroit Edison Community Lighting Group prepared and submitted proposed plans to install street lighting for the Tremont Subdivision, Ypsilanti Township, consisting of 188 parcels, which said plans included, *inter alia*, the installation of fifteen (15) "**new 60 watt Granville LED with gold ribs and bands**" and the conversion to LED of twenty-four (24) "**existing 100 watt HPS acorns with gold ribs and bands to be converted to 60 watt Granville LED with gold ribs and bands**" with the cost of said improvements being approximately:

Total Estimate Construction Cost:	\$80,966.90
Total Lamp Charge For Three (3) Years:	\$13,875.75
Contribution (Cost minus 3 years revenue):	\$67,091.15
Total Annual Lamp Charges:	\$ 4,625.25

WHEREAS, on October 26, 2016 the Township Clerk received notification from the Township Assessor that the cost of providing street lights for the Tremont Subdivision, Ypsilanti Township, consisting of 188 parcels, which said plans included, *inter alia*, the installation of fifteen (15) "**new 60 watt Granville LED with gold ribs and bands**" and the conversion to LED of twenty-four (24) "**existing 100 watt HPS acorns with gold ribs and bands to be converted to 60 watt Granville LED with gold ribs and bands**" will be **\$60.29** per parcel for a 10-year period; thereafter, said costs shall be estimated at **\$24.60** per parcel for street lighting, based on general benefit; and

WHEREAS, the Township Clerk has given notice to each record owner of or party in interest in property to be assessed, by first class mail, addressed to the record owner or party in interest at the address shown on the tax records, at least 10 (ten) days before the December 6, 2016 public hearing, setting forth the district affected in said petition, place and purpose of said public hearing to allow any interested person an opportunity to voice any objection which may be offered against creating said district; and

WHEREAS, the Township Clerk has also published in a newspaper of general circulation the time, place and purpose of said public hearing and the district affected thereto; and

WHEREAS, on December 6, 2016, the Charter Township of Ypsilanti held a public hearing to hear any objections which may be offered against creating said special assessment district.

NOW THEREFORE, BE IT RESOLVED, that the Charter Township of Ypsilanti determines that the petition filed by the record owners of the Tremont Subdivision, consisting of 188 parcels, on October 6, 2016, is sufficient for all purposes set forth pursuant to Act 188 of the Public Acts of 1954, as amended.

BE IT FURTHER RESOLVED, that a special assessment district be created for the purpose of providing street lights for the Tremont Subdivision, consisting of 188 parcels.

BE IT FURTHER RESOLVED, that the Township Board accepts the plans and estimate of costs as presented by Detroit Edison for the Tremont Subdivision, consisting of 188 parcels, which said plans included, *inter alia*, the installation of fifteen (15) **“new 60 watt Granville LED with gold ribs and bands”** and the conversion to LED of twenty-four (24) **“existing 100 watt HPS acorns with gold ribs and bands to be converted to 60 watt Granville LED with gold ribs and bands”** will be **\$60.29** per parcel for a 10-year period; thereafter, said costs shall be estimated at **\$24.60** per parcel for street lighting, based on general benefit.

BE IT FURTHER RESOLVED, that the Township Supervisor shall make a special assessment upon all the lands and premises contained herein to defray the expenses of lighting said streets.

BE IT FURTHER RESOLVED, that the Township Board shall hereinafter annually determine on or before September 30 of each year, the amount to be assessed in said district for lighting said streets and shall direct the Township Assessor to levy such amounts therein.

BE IT FURTHER RESOLVED, that when the special assessment roll has been prepared and filed in the office of the Township Clerk, before said assessment roll has been confirmed, the Township Board shall appoint a time and place when it will meet, review and hear any objections to the assessment roll.

BE IT FURTHER RESOLVED, that the Township Board shall give notice of said hearing and filing of the assessment roll in the manner prescribed by statute.

Supervisor
BRENDA L. STUMBO
Clerk
KAREN LOVEJOY ROE
Treasurer
LARRY J. DOE
Trustees
JEAN HALL CURRIE
STAN ELDRIDGE
MIKE MARTIN
SCOTT MARTIN



Charter Township of Ypsilanti

Clerk's Office

7200 S. Huron River
Drive
Ypsilanti, MI 48197
Phone: (734) 484-4700
Fax: (734) 484-5156

November 17, 2016

Property Owner
Address
City, State Zip

Re: Public Hearing Scheduled for Tuesday, December 6, 2016 at Approximately 7:00pm for the Creation of a New Special Assessment Streetlight District for the Tremont Subdivision (Phase 1 and 2)

Dear Property Owners:

Please be advised that the Charter Township of Ypsilanti Board of Trustees set a public hearing to consider the request for the creation of a special assessment streetlight district for the Tremont Subdivision. This district will include the addition of fifteen (15) LED streetlights and the conversion of twenty-four (24) streetlights to LED.

Signatures on the petitions received from your subdivision were verified and meet the 51% criteria necessary to create a district.

The public hearing will be held on Tuesday, December 6, 2016 at approximately 7:00 p.m. in the Civic Center Board Room, 7200 S. Huron River Drive, Ypsilanti Township.

The Detroit Edison lamp layout for the proposed new streetlights and LED conversion is located on the back of this letter. The cost for each parcel in the assessment district will be approximately \$60.29 for ten (10) years. Once the installation costs are paid at the end of the ten (10) years, the annual amount will drop to approximately \$24.60, based on DTE's current costs.

You are welcome to attend the meeting or you may send written comments of approval or objection in advance of the public hearing to the address listed above or by email to klovejoyroe@ytown.org or lgarrett@ytown.org.

To Legally Protest the Streetlight Special Assessment:

An owner or party in interest, or his or her agent, may appear in person at the hearing to protest the special assessment in person, or may file his or her appearance and protest by letter before the hearing, and in that event, personal appearance shall not be required. The owner or any person having an interest in the real property who protests in writing at or before the hearing may file a written appeal of the special assessment with the State Tax Tribunal within 30 days after the special assessment roll is confirmed.

If you have any questions or need additional information, please feel free to contact my office.

Sincerely,

Karen Lovejoy Roe, Clerk

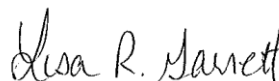
Deputy Clerk

Irg
cc: File

Supervisor
BRENDA L. STUMBO
Clerk
KAREN LOVEJOY ROE
Treasurer
LARRY J. DOE
Trustees
JEAN HALL CURRIE
STAN ELDRIDGE
MIKE MARTIN
SCOTT MARTIN



Charter Township of Ypsilanti

Assessor's Office

7200 S. Huron River Drive
Ypsilanti, MI 48197
Phone: (734) 487-4927
Fax: (734) 484-5159

Date: October 26, 2016

To: Karen Lovejoy Roe,
Ypsilanti Township Clerk

From: Brian McCleery,
Assistant Assessor

+
Subject: Cost Allocations – Tremont Park Streetlight District 208

The Tremont Park Streetlight Special Assessment District #208 is comprised of 188 parcels in which the costs of construction and operating costs are to be divided equally.

Installation Costs-

The installation costs for the 15 Streetlights total \$67,091.15. This total is divided among the 188 parcels and is spread over a 10 year period starting in 2017 and expiring in 2026. The annual cost per parcel for installation is **\$35.69**.

Annual Lamp Charges-

DTE has fixed the annual lamp charges for the first three years, per agreement to \$4,625.25. This cost is divided among the 188 parcels and equals **\$24.60** per parcel. After the third year the cost will reflect the current rates set by DTE as well as the current electrical usage over the year.

Total Street Light Special Assessment-

During the first 10 years it is estimated that the annual cost for the new street lights per parcel would be **\$60.29**. Once the installation costs are paid off in 10 years, the cost will reflect the updated Annual Lamp Charges. An Estimate of the annual cost per parcel based upon DTE's current costs would be \$24.60 per parcel.

PUBLIC NOTICE

Public act 1088 of 1954 proceedings – Notice of Special Assessment Hearing
Charter Township of Ypsilanti, Washtenaw County, Michigan

To: **The residents and property owners of the Charter Township of Ypsilanti, Washtenaw County, Michigan and any other interested persons**

PLEASE TAKE NOTICE that as a result of petitions of property owners within the township, signed by the record owners of land whose area or footage constitutes more than 50% of the total of the hereinafter described Tremont Subdivision, the Charter Township of Ypsilanti Board of Trustees proposes to install LED streetlights and convert current streetlights to LED and to create a special assessment for the recovery of the cost thereof by special assessment against the properties benefited therein.

PLEASE TAKE FURTHER NOTICE that the district within, which the foregoing improvements are proposed to be constructed and within which the cost thereof is proposed to be assessed is more particularly described as follows:

TREMONT SUBDIVISION

PLEASE TAKE FURTHER NOTICE that said plans, special assessment district and petitions may be examined at the office of the Township Clerk from the date of this notice until and including the date of the public hearing hereon and may further be examined at such public hearing.

PLEASE TAKE FURTHER NOTICE that a public hearing upon such petitions, plans, district and estimate of cost will be held at the Charter Township of Ypsilanti Civic Center, 7200 S. Huron River Drive, Ypsilanti Township, MI commencing at approximate **7:00 p.m. on Tuesday, December 6, 2016.**

At such hearing, the Board will consider any written objections to any of the foregoing matters which might be filed with said Board at or prior to the time of said hearing as well as any revision, corrections, amendments or changes to said plans, estimate and cost or to said special assessment district.

All interested persons are invited to be present at the aforesaid time and place and to submit comments concerning any of the foregoing.

An owner or party in interest, or his or her agent, may appear in person at the hearing to protest the special assessment in person, or may file his or her appearance and protest by letter before the hearing, and in that event, personal appearance shall not be required. The owner or any person having an interest the real property who protests in writing at or before the hearing may file a written appeal of the special assessment with the State Tax Tribunal within 30 days after the special assessment roll is confirmed.

If the special assessment roll is confirmed, the Township Board intends to hold a public hearing once each year in future years to reassess property in the special assessment district for the costs in the next year, and will provide notice of such hearing by publication in the newspaper only, unless the amount to be specially assessed increases by more than 10 percent in any one year, then mailed notice of the public hearing will be provided to owners of property to be specially assessed.

The Charter Township of Ypsilanti will provide necessary reasonable auxiliary aids and services such as signers for the hearing impaired and audio tapes of printed materials being considered at the meeting or public hearing in individuals with disabilities upon 10 day notice to the Township Board by writing or calling Karen Lovejoy Roe, Clerk, 7200 S. Huron River Drive, Ypsilanti, MI 48197, (734) 484-4700, fax (734) 484-5156 or email klovejoyroe@ytown.org.

KAREN LOVEJOY ROE, CLERK
CHARTER TOWNSHIP OF YPSILANTI

PUBLISHED: Thursday, November 21, 2016

Exhibit A to Master Agreement

Purchase Agreement

This Purchase Agreement (this "Agreement") is dated as of October 25, 2016 between The Detroit Edison Company ("Company") and Charter Township of Ypsilanti ("Customer").

This Agreement is a "Purchase Agreement" as referenced in the Master Agreement for Municipal Street Lighting dated March 28, 2013 (the "Master Agreement") between Company and Customer. All of the terms of the Master Agreement are incorporated herein by reference. In the event of an inconsistency between this Agreement and the Master Agreement, the terms of this Agreement shall control.

Customer requests the Company to furnish, install, operate and maintain street lighting equipment as set forth below:

1. DTE Work Order Number:	41642813	
	If this is a conversion or replacement, indicate the Work Order Number for current installed equipment: N/A	
2. Location where Equipment will be installed:	Tremont Subdivision located at the intersection of Martz Rd & Tremont Blvd, as more fully described on the map attached hereto as <u>Attachment 1</u> .	
3. Total number of lights to be installed:	15 – New 60 watt Granville LED with gold ribs and bands. 24 – Existing 100 watt HPS acorns with gold ribs and bands to be converted to 60 watt Granville LED with gold ribs and bands.	
4. Description of Equipment to be installed (the " <u>Equipment</u> "):	Install (15) new 60 watt Granville acorn LED fixtures with black housings and gold band, gold ribs, and lunar optics. Fixtures to be mounted on new stock black 11'6" Mainstreet black fluted posts on concrete foundations. Convert (24) – 100 watt High Pressure Sodium fixtures with 60 watt Granville LED fixtures with black housings and gold band, gold ribs, and lunar optics mounted on existing posts.	
5. Estimated Total Annual Lamp Charges	\$4,625.25 (\$308.35 X 15 – New Lamp Charges – 3 Year Credit) \$7,400.40 (\$308.35 X 24 – Conversions – No 3 Year Credit)	
6. Computation of Contribution in aid of Construction (" <u>CIAC Amount</u> ")	Total estimated construction cost, including labor, materials, and overhead:	\$80,966.90
	Credit for 3 years of lamp charges:	\$13,875.75
	CIAC Amount (cost minus revenue)	\$67,091.15
7. Payment of CIAC Amount:	Due promptly upon execution of this Agreement	
8. Term of Agreement	5 years. Upon expiration of the initial term, this Agreement shall continue on a month-to-month basis until terminated by mutual written consent of the parties or by either party with thirty (30) days prior written notice to the other party.	
9. Does the requested Customer lighting design meet IESNA recommended practices?	(Check One) <input type="checkbox"/> YES <input checked="" type="checkbox"/> NO If "No", Customer must sign below and acknowledge that the lighting design does not meet IESNA recommended practices Signature: _____	
10. Customer Address for Notices:	Charter Township of Ypsilanti 7200 S Huron River Dr Ypsilanti, MI 48197 Attn: Karen Lovejoy Roe	

11. Special Order Material Terms:

All or a portion of the Equipment consists of special order material: (check one) YES NO

If "Yes" is checked, Customer and Company agree to the following additional terms.

A. Customer acknowledges that all or a portion of the Equipment is special order materials ("SOM") and not Company's standard stock. Customer will purchase and stock replacement SOM and spare parts. When replacement equipment or spare parts are installed from Customer's inventory, the Company will credit Customer in the amount of the then current material cost of Company standard street lighting equipment.

B. Customer will maintain an initial inventory of at least 0 posts and 2 luminaires and any other materials agreed to by Company and Customer, and will replenish the stock as the same are drawn from inventory. Costs of initial inventory are included in this Agreement. The Customer agrees to work with the Company to adjust inventory levels from time to time to correspond to actual replacement material needs. If Customer fails to maintain the required inventory, Company, after 30 days' notice to Customer, may (but is not required to) order replacement SOM and Customer will reimburse Company for such costs. Customer's acknowledges that failure to maintain required inventory could result in extended outages due to SOM lead times.

C. The inventory will be stored at **Ypsilanti Township Barn at 7200 S Huron River Dr., Ypsilanti, MI 48197**. Access to the Customers inventory site must be provided between the hours of 9:00 am to 4:00 pm, Monday through Friday with the exceptions of federal Holidays. Customer shall name an authorized representative to contact regarding inventory: levels, access, usage, transactions, and provide the following contact information to the Company:

Name: **Jeff Allen**

Title: **Residential Services Director**

Phone Number: **Cell 734.368.1125**

Email: **jallen@ytown.org**

The Customer will notify the Company of any changes in the Authorized Customer Representative. The Customer must comply with SOM manufacturer's recommended inventory storage guidelines and practices. Damaged SOM will not be installed by the Company.

D. In the event that SOM is damaged by a third party, the Company may (but is not required to) pursue a damage claim against such third party for collection of all labor and stock replacement value associated with the damage claim. Company will promptly notify Customer as to whether Company will pursue such claim.

E. In the event that SOM becomes obsolete or no longer manufactured, the Customer will be allowed to select new alternate SOM that is compatible with the Company's existing infrastructure.

F. Should the Customer experience excessive LED equipment failures, not supported by LED manufacturer warranties, the Company will replace the LED equipment with other Company supported Solid State or High Intensity Discharge luminaires at the Company's discretion. The full cost to complete these replacements to standard street lighting equipment will be the responsibility of the Customer.

12. Experimental Emerging Lighting Technology (“EELT”) Terms:

All or a portion of the Equipment consists of EELT: (check one) YES NO

If “Yes” is checked, Customer and Company agree to the following additional terms.

A. The annual billing lamp charges for the EELT equipment has been calculated by the Company are based upon the estimated energy and maintenance cost expected with the Customer’s specific pilot project EELT equipment. .

B. Upon the approval of any future MPSC Option I tariff for EELT street lighting equipment, the approved rate schedules will automatically apply for service continuation to the Customer under Option 1 Municipal Street Lighting Rate, as approved by the MPSC. The terms of this paragraph B replace in its entirety Section 7 of the Master Agreement with respect to any EELT equipment purchased under this Agreement.

Company and Customer have executed this Purchase Agreement as of the date first written above.

Company:

Customer:

The Detroit Edison Company

Charter Township of Ypsilanti

By: _____

By: _____

Name: _____

Name: _____

Title: _____

Title: _____

Attachment 1 to Purchase Agreement

Map of Location

[To be attached]

□ - EXISTING LIGHT LOCATION - 24 TOTAL

□ - NEW LIGHT LOCATION - 15 TOTAL

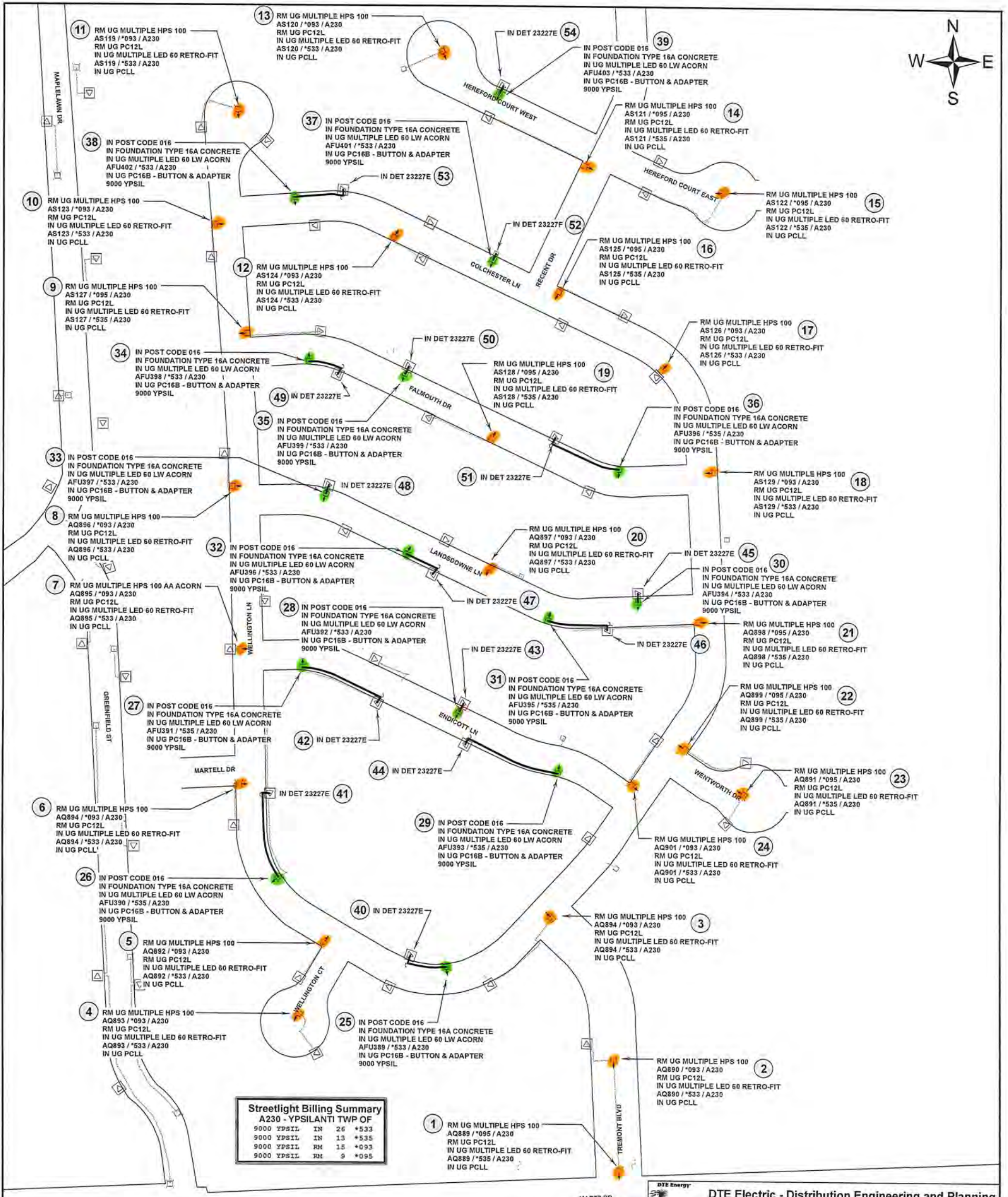

EXHIBIT "B"



DTE Energy		DTE Electric - Distribution Engineering and Planning					
Service Planner	Work Order Description	SL UG IN 15-60W LED, RP 24-100W HPS W80W LED Tremont Sub-Ypsi Twp					PLC
Wheel, Thomas J	Work Order #	45926576	GIS-DIST	COB	CUE	CLD	Sub
Phone	Project #		Group #2				SCMAT
586.412.3028	Project #1						
Supervisor	Service Center	Worksite City	Worksite Twp	County			
Brian R. Klineck	ANN	Ypsilanti	Ypsilanti	Washtenaw			
Phone	Work to be performed						
734.397.4024							
Planning Engineer	DU Company	Contact	Email	Phone			
	DU Company	Contact	Email	Phone			
Phone	CUE Number	Ver	Plot Date	State	Town	Range	Section
	668057	1	10/5/2016	MI	035	07E	35

PUBLIC COMMENTS

CONSENT AGENDA

**CHARTER TOWNSHIP OF YPSILANTI
MINUTES OF THE NOVEMBER 15, 2016 WORK SESSION**

Supervisor Stumbo called the meeting to order at approximately 5:33 p.m. in the Ypsilanti Township Civic Center Board Room, 7200 S. Huron River Drive, Ypsilanti Township.

Members Present: Supervisor Brenda L. Stumbo, Clerk Karen Lovejoy Roe, Treasurer Larry Doe, Trustees: Stan Eldridge, Scott Martin, M. Martin

Members Absent: Trustee Jean Hall Currie

Legal Counsel: Wm. Douglas Winters

1. FULL TIME ELECTED, OR APPOINTED OFFICIALS WORK ATTENDANCE, WORK HOURS & TIME OFF POLICY.....TRUSTEE ELDRIDGE

Trustee Eldridge asked to have this item removed from the Agenda. Supervisor Stumbo asked if that was accepted by the board and they replied that it was.

Arloa Kaiser, Township Resident stated she was disappointed in the decision to remove the attendance policy from the work session. She said she knows why you did it because it makes you accountable and it's now okay for you to lie.

Supervisor Stumbo addressed Ms. Kaiser directly and said there could be nothing further from the truth.

Attorney Winters stated that a half hour earlier the new Township Board Officials, along with the Park Commissioners and other Officials in the Township took an oath of office to uphold the Constitution of the State of Michigan, the Constitution of the United States, and Ypsilanti Township Ordinances and the oath carries with it a responsibility to fulfill your duties and those duties are very specific. He said the Township Board Officials are elected and are not township employees. Attorney Winters stated there was nothing he could do as the Township Attorney to say they have to do certain things that are required of a township employee. He said every four years they come up for a job performance review by the people in this township and if the people feel they are not doing their job there was the ultimate job performance evaluation and it's called an election. Attorney Winters said that

**CHARTER TOWNSHIP OF YPSILANTI
NOVEMBER 15, 2016 WORK SESSION MINUTES
PAGE 2**

all elected officials in the State of Michigan do not work the same amount of time but they all have taken the same oath. He said that Township Officials have responsibility 24/7 and work a lot of evenings and weekends and there was no clock to punch. He said this was how the State of Michigan set it up for their elected officials to conduct business. He said the ethics of each elected official would be evaluated by the voters.

Arloa Kaiser, Township Resident stated that the politicians once in office make the rules. She said very few people come to a meeting to see what's going on and they just check a box when they vote.

Supervisor Stumbo stated she appreciated what Trustee Eldridge was trying to do and she would continue to serve in a professional manner.

Arloa Kaiser, Township Resident stated she would like to thank Trustee Scott Martin and Trustee Mike Martin for their extremely good and consistent hard work.

2. SNOW REMOVAL ORDINANCE.....MIKE RADZIK AND JEFF ALLEN

Supervisor Stumbo stated that after discussing this ordinance in a staff meeting they had decided to continue the discussion in the work session. Jeff Allen, Residential Services Director discussed this ordinance with Mike Radzik, OCS Director and he said the implementation would be difficult because there were no contractors set up for snow removal. Supervisor Stumbo stated that with the offices closed during the holidays there would be no one working to enforce it. Trustee S. Martin said that with the new program with the inspecting of multi-family it takes a lot of manpower and it would be good to bring it back in the future when it could be instituted properly. Mike Radzik stated his concern was with no accumulation set for sidewalks in the ordinance and they could get complaints with a dusting of snow on sidewalks. Mr. Radzik said another problem might be if we send a contractor out to shovel one house we had a complaint for and there were other houses with snow on the sidewalks that there wasn't a complaint called in for, we would be making and paying for several visits to possibly the same area. He said he and Jeff have been trying to come up with an outreach program to try and

**CHARTER TOWNSHIP OF YPSILANTI
NOVEMBER 15, 2016 WORK SESSION MINUTES
PAGE 3**

get people to shovel their sidewalks without code enforcement. Supervisor Stumbo said she would like to get information to residents when its' a snow emergency so they could move their cars off the road so the entire road would be plowed but the road commission doesn't give a warning. Treasurer Doe said that he would like a letter sent to residents explaining the process for snow removal.

Jo Ann McCollum, Township Resident said in West Willow they are working with Steven Wade from the Washtenaw County Public Health on a mini grant to hire youth for snow removal and lawn care and maybe it could be a Township wide program.

Supervisor Stumbo said she would like to pilot a program and identify people who are not able to do it because she feels that about 90% of the residents do take care of their walks and maybe there was a reason why the other 10% can't do it. She said that we could figure out a way to help them if they were not able. Supervisor Stumbo stated that in order to have a healthy community people would need to be able to walk in the winter and they need cleared sidewalks for it to be safe.

Monica Ross-Williams, Trustee Elect stated that the news organizations put out warnings if there were a snow emergency. She also suggested Text Alerts.

Clerk Lovejoy Roe read other ordinances regarding snow removal from other communities and suggested a committee be formed to work on a policy for snow removal. Mike Radzik, OCS Director said he would like to get an idea on the percent of residents in neighborhoods which were not shoveling their snow without having an ordinance and find out whether one was needed.

3. COMPOST SITE UPDATE.....JEFF ALLEN

Jeff Allen, Residential Services Director stated the proposal was to change the hours for the Composite Site to 8am – 4pm instead of 9am-5pm because waste management trucks begin at 7am and we could get the trucks in and out more efficiently. He said the Saturday hours would be the same. Mr. Allen said the prices haven't changed but they were having difficulty getting rid of the oil and anti-freeze they have collected from residents. He said the oil places are sending oil to

**CHARTER TOWNSHIP OF YPSILANTI
NOVEMBER 15, 2016 WORK SESSION MINUTES
PAGE 4**

be tested to make sure it was safe and that takes a few days and there was added cost unlike in earlier years when we were paid a small amount to take it now it was a cost to us.

4. AGENDA REVIEW

CONSENT AGENDA

A. MINUTES OF THE NOVEMBER 1, 2016 WORK SESSION AND REGULAR MEETING

B. STATEMENTS AND CHECKS

1. STATEMENTS AND CHECKS FOR NOVEMBER 15, 2016 IN THE AMOUNT OF \$1,099.440.30

2. CHOICE HEALTH CARE DEDUCTIBLE ACH EFT FOR OCTOBER 2016 IN THE AMOUNT OF \$25,357.61

3. CHOICE HEALTH CARE ADMIN FEE FOR SEPTEMBER 2016 IN THE AMOUNT OF \$1,200.00

C. OCTOBER 2016 TREASURER'S REPORT

5. SUPERVISOR REPORT

Supervisor Stumbo reported on meetings she attended in the last 2 weeks. She said she and Attorney Winters met to discuss the agreement for the Willow Run Arsenal for Democracy development agreement on October 20, 24 and 25, 2016 and it was approved by the Township Board at the November 1, 2016 meeting. Supervisor Stumbo said she and Treasurer Doe met with Meals on Wheels and they provided an update on the service in Ypsilanti Township and said they were trying to make healthier and better quality food. Supervisor Stumbo stated it was the intent to use the payment of \$1 million from the WRAD/ACM Development Agreement to pay the Tyler Pond assessment for the Township property owners. Supervisor Stumbo

CHARTER TOWNSHIP OF YPSILANTI
NOVEMBER 15, 2016 WORK SESSION MINUTES
PAGE 5

stated she hosted the Big 20 Township Supervisors meeting which was for the top 20 largest populated Townships on October 21, 2016. She said it was a great meeting and she handed out copies of our Budget because the other Supervisors had never seen a line item budget like we have. She reported she attended several neighborhood watch meetings for Gault Village, Thurston, Lay Gardens, West Willow, Lincoln, and Wingate. She reported she attended YCUA and Police meeting also. Supervisor Stumbo said on October 25, 2016 she attended the Executive Briefing for Professional Development with Mike Kesley and it was about the new federal law regarding employees and the hours they work. Supervisor Stumbo met with Marie Miter who works with EMU and is the Afterschool Alliance Ambassador for Ypsilanti Community Schools. She said they have a program in Holmes School where they work with the kids after school and provide educational opportunities and recreational activities. Supervisor Stumbo said she was on the memorial committee for the 25th anniversary for the Viet Nam Veterans Memorial and the ceremony was held on Thursday, November 10, 2016. She said Clerk Lovejoy Roe, Trustee Eldridge, and Trustee Elect Heather Roe attended the event. Supervisor Stumbo said the Veterans appreciate the Township and its' commitment to the Veterans and she said they were getting older and hoped we would continue to take care of this memorial. Supervisor Stumbo said she attended an Eastern Washtenaw Safety Alliance meeting which helps to get the public safety people and the community to work together with community events, as well as police enforcement. Supervisor Stumbo said she had a meeting with Magistrate Mark Nelson about security at 14B Court. She said 14B was the only court in Washtenaw County that doesn't have security. She said the Township would need capital and operational cost for implementation and she said it would be brought back to the board for approval. Supervisor Stumbo said she, Treasurer Doe, and Joe Lawson, Planning Director met with Tony Dixson about a potential development on Huron Street. Supervisor Stumbo said we had the election on November 8, 2016 and had one incident at the Moose Lodge which was not reflective of our community. She said the election ran extremely well other than that one incident. Supervisor Stumbo stated she appreciated all the help they have for the elections. She reported she had a meeting with Robin Castle-Hine and Mike Radzik on November 9, 2016 regarding the issue of cars left overnight at our parks. Supervisor Stumbo said they don't want to tow them since it would be very expensive for them. She said they decided to leave a note on the car with the non-emergency number to

CHARTER TOWNSHIP OF YPSILANTI
NOVEMBER 15, 2016 WORK SESSION MINUTES
PAGE 6

have someone come and unlock the gate but they would still receive a ticket. She said she attended a Development Team meeting and met with Greg Dill who is the new Administrator for Washtenaw County. She said Mr. Dill was interested in working with the Township on economic development and recreation on the eastside. She said Mr. Dill was a resident of Ypsilanti Township. Supervisor Stumbo reported she met with Luke Bonner who works for Aerotropolis who offered to schedule a meeting with Joe Lawson, Planning Director and our development team to help the township find ways to plan for economic development and help market development. She said he would help create a marketing brochure for Ypsilanti Township.

6. CLERK REPORT

Clerk Lovejoy Roe reported 6,637 absentee ballots were mailed out and 6,441 were returned and voted. She said that over 1,000 of those ballots were processed in two days by the Clerks office. Clerk Lovejoy Roe said there were 42,153 registered voters in Ypsilanti Township and 20,280 voters went to the polls on election day. She said that the total number people voting, including absentee, in Ypsilanti Township was 26,721 or 63.4% of registered voters voted. She said some of our precincts saw over 75-78% turn out but the average was 63.4%. She said with elections inspectors, set up people, and township staff there were close to 200 people who worked the election. She said they tried to put 8 inspectors at each precinct and some of the bigger precincts had 9. She said that people call off so she had a standby crew and ended up using them so she could fully staff each precinct as planned. Clerk Lovejoy Roe said that they planned well for this election with only a few minor complaints. She said that with the table top booths that were used she doubled the number of voting booths at every precinct which helped tremendously in moving the lines more efficiently. Clerk Lovejoy Roe stated that 9 of the precincts also had 2 computers which helped with the flow of voters. She said that because the state wants to end straight party voting ticket, the Michigan Bureau of Elections asked us to keep track on how many voters were in line each hour the polls were open. She said at the busiest hours the lines across the Township only had about 75 people in line. Clerk Lovejoy Roe thanked all the department heads in allowing some of their staff to help work the election. She said that Jeff Allens' staff did a great job because they were putting up twice as much equipment as they

**CHARTER TOWNSHIP OF YPSILANTI
NOVEMBER 15, 2016 WORK SESSION MINUTES
PAGE 7**

usually do for elections. Clerk Lovejoy Roe said that her department does not process passports during the election because they are busy with absentee voters but the Thursday night before the election the Clerk's Office processed 68 passports for Eastern Michigan University Football team because if they won one more game which was scheduled for Saturday, November 5, 2016 they would be going to the Bahama Bowl in December. Clerk Lovejoy Roe stated she, Supervisor Stumbo, and Trustee Eldridge went to a celebration honoring Linda Mealing who had been a very strong leader in West Willow. She said Ms. Mealing was stepping down from being an Officer in the West Willow Neighborhood organization. Clerk Lovejoy Roe said a few days later, after the meeting honoring Linda Mealing she saw Ms. Mealing's van pulled to the side of the road and she was out picking up trash on the side of the road. Clerk Lovejoy Roe stated that this meeting would be the last meeting Trustee Scott Martin and Trustee Mike Martin would be on the Board and she said it was a pleasure serving with them and they would be missed.

7. TREASURER REPORT

Treasurer Doe thanked Trustee Mike Martin and Trustee Scott Martin for serving on the board and he said he enjoyed working with them and although he was glad to see the new Trustees he would miss them very much. He said he hopes to see them in the future.

8. TRUSTEE REPORT – WILL BE PRESENTED IN THE REGULAR MEETING

9. ATTORNEY REPORT

A. GENERAL LEGAL UPDATE

Attorney Winters stated the Township negotiated the \$1 million dollar payment from the Willow Run Arsenal Democracy to be applied to the Tyler Dam and Tyler Pond construction project. He said the closing occurred on November 4, 2016 and on Monday, November 14, 2016 he contacted WRAD about the payment and \$700,000.00 was wired to the township and the remaining \$300,000.00 would be paid in December, 2016. He said the Township should receive the payment of \$334,000.00 from SBA Communications for the cell tower on Cadillac Avenue by

**CHARTER TOWNSHIP OF YPSILANTI
NOVEMBER 15, 2016 WORK SESSION MINUTES
PAGE 8**

the end of this year. Attorney Winters said the \$334,000.00 would be applied to the Seaver Farm bond debt. He said the Township continues to have ongoing development related matters with regards to limited partnerships looking to submit offers to the Township in the near future on some township owned properties. He said some of these offers might be brought to the Board as early as December, 2016. Attorney Winters said that in regards to Gault Village, the Court did appoint a Receiver, Attorney Carl Fink, a former Judge. He said that he thinks they have installed the gate behind the shopping center to try and stop the illegal dumping and we would continue to work on this project hoping that in the next 12 months we would get something positive going on with redeveloping the property. Attorney Winters thanked Trustee Scott Martin and Trustee Mike Martin for their support over the years and said they have done a lot of work for the Township over years and he said he appreciates their commitment.

OLD BUSINESS

- 1. RESOLUTION 2016-44, SUPERVISOR'S WAGE**
(TABLED AT THE NOVEMBER 1, 2016 REGULAR MEETING)
- 2. RESOLUTION 2016-45, CLERK'S WAGE**
(TABLED AT THE NOVEMBER 1, 2016 REGULAR MEETING)
- 3. RESOLUTION 2016-46, TREASURER'S WAGE**
(TABLED AT THE NOVEMBER 1, 2016 REGULAR MEETING)

NEW BUSINESS

- 1. BUDGET AMENDMENT #16**

Clerk Lovejoy Roe explained Budget Amendment #16.

**CHARTER TOWNSHIP OF YPSILANTI
NOVEMBER 15, 2016 WORK SESSION MINUTES
PAGE 9**

**2. RESOLUTION 2016-57, AUTHORIZING THE DIVISION OF PLATTED LOTS IN
THE WASHTENAW CLUBVIEW SUBDIVISION**

Supervisor Stumbo stated that a Resident requested subdivided platted lots and had gone through the Planning Department and had met the requirements.

**3. RESOLUTION 2016-59, AUTHORIZING THE ROAD NAME CHANGE OF RILEY
COURT TO HARVEY PLACE**

Supervisor Stumbo stated this was a request to change the name of a private road in Ypsilanti Township. Trustee Eldridge asked if the Township incurred the cost for the street sign to be changed. Supervisor Stumbo said it was a private road so they would pay for the signs. Attorney Winters stated there have been a number of issues over the years regarding Riley Court Apartments and wonder if dispatch for the Sheriff would know the new street name. Mike Radzik, Director of OCS said he and Lt. Marocco were just discussing that the emergency services would need to be notified of the name change. Mr. Radzik said that Riley Ct. was not a private road but a private driveway back to the apartments. Attorney Winters questioned what the benefit would be to change the name and what the intent would be in changing the name. Clerk Lovejoy Roe said when looking into it she felt it was the same as when Lake in the Woods changed the name of their road to Lakeshore Blvd. Mike Radzik said the letter from the owner in the packet said he was rebranding it. Supervisor Stumbo asked Chief Copeland if his department dealt in the name changes of streets. Chief Copeland stated they were part of the process and he would go and do site assessment. Supervisor Stumbo said that she remembered the Marriott having the road changed from Whittaker Road to Huron Street in front of the hotel. Clerk Lovejoy Roe said they planned on notifying all the emergency agencies and in the old Resolution it stated the State Treasury Department needed to be notified. Mike Radzik said the parcel of land has an East Michigan Ave. address but the apartments have a Riley Ct. address and the Post Office delivers to Riley Ct. Supervisor Stumbo asked Chief Copeland if he had an objection to changing the name of Riley Court to Harvey Place. Chief Copeland said he did not object but thought the apartment name was changed also. Lt. Marocco said that the name has been changed but they still refer to it as Riley Court

**CHARTER TOWNSHIP OF YPSILANTI
NOVEMBER 15, 2016 WORK SESSION MINUTES
PAGE 10**

Apartments. Attorney Winters stated that if the Chief and the Lt. were satisfied he didn't have an objection.

- 4. REQUEST FOR AUTHORIZATION TO SIGN PURCHASE AGREEMENT WITH DTE FOR THE INSTALLATION OF TWO (2) OVERHEAD FED 135 WATT AUTOBAHN LED FIXTURES WITH GRAY HOUSINGS MOUNTED ON 17' 6" STEEL ARMS ATTACHED TO TWO NEW WOOD POLES IN THE AMOUNT OF \$4,174.42 TO BE LOCATED AT THE BUS STOP ON ECORSE RD. BETWEEN REDWOOD AVENUE AND ROSEWOOD AVENUE BUDGETED IN LINE ITEM #101-956-000-926-050**

- 5. REQUEST FOR AUTHORIZATION TO SIGN THE PURCHASE AGREEMENT WITH DTE FOR THE INSTALLATION OF ONE (1) OVERHEAD FED 135 WATT AUTOBAHN LED FIXTURE WITH GRAY HOUSINGS MOUNTED ON 17'6" STEEL ARM ATTACHED TO A NEW WOOD POLE IN THE AMOUNT OF \$1,988.61 BUDGETED IN LINE ITEM #101-956-000-926-050**

Supervisor Stumbo stated that these were for Streetlights on Ecorse and Grove Road.

OTHER BUSINESS

AUTHORIZATIONS AND BID

- 1. REQUEST OF ANGELA VERGES, RECREATION SUPERINTENDENT TO SEEK BIDS FOR THE PRINTING OF THE "DISCOVER YPSILANTI TOWNSHIP RECREATION GUIDE"**

- 2. REQUEST OF TRAVIS MCDUGALD, IS MANAGER TO ACCEPT THE LOW PROPOSAL FROM CLEARRATE COMMUNICATION TO PROVIDE TELEPHONE UTILITY SERVICES IN THE AMOUNT OF \$618.00 PER MONTH AND TO AUTHORIZE SIGNING OF NECESSARY DOCUMENTS CONTINGENT UPON ATTORNEY REVIEW**

**CHARTER TOWNSHIP OF YPSILANTI
NOVEMBER 15, 2016 WORK SESSION MINUTES
PAGE 11**

- 3. REQUEST OF TRAVIS MCDUGALD, IS MANAGER TO ACCEPT THE LOW PROPOSAL OBTAINED THROUGH THE MICHIGAN INTERGOVERNMENTAL TRADE NETWORK (MITN) FOR THE PURCHASE OF WINDOWS SERVER 2016 LICENSING FROM CIVITAS IT IN THE AMOUNT OF \$26,043.68 BUDGETED IN LINE ITEM #101-266-000-977-001**

The Board adjourned the work session meeting at approximately 6: 55 p.m.

Respectfully Submitted,

Karen Lovejoy Roe, Clerk

CHARTER TOWNSHIP OF YPSILANTI
MINUTES OF THE NOVEMBER 15, 2016 REGULAR BOARD MEETING

Supervisor Stumbo called the meeting to order at approximately 7:08 p.m. in the Ypsilanti Township Civic Center Board Room, 7200 S. Huron River Drive, Ypsilanti Township.

Members Present: Supervisor Brenda L. Stumbo, Clerk Karen Lovejoy Roe, Treasurer Larry Doe, Trustees: Stan Eldridge, Scott Martin, M. Martin

Members Absent: Trustee Jean Hall Currie

Legal Counsel: Wm. Douglas Winters

PUBLIC COMMENTS

Jo Ann McCollum, Township Resident thanked the Board for acknowledging Linda Mealing. She said Ms. Mealing was a foundation for West Willow and they appreciate her. Ms. McCullum said that Ms. Mealing was actually surprised by the celebration because they had kept it a secret from her.

Arloa Kaiser, Township Resident thanked Trustee Scott Martin and Trustee Mike Martin for the hard work they have done for the township and for her as a resident of the township. She said she was saddened to see that the business regarding the three elected full time officials that the time off and hours they put in are not scrutinized more. She said it was a known fact that when you take a job like yours that extra time and that type of thing goes along with it and it was not included in your salary but you should be required certain amount of time delivered to the people to serve the people and vacation time should not be unlimited.

Monica Ross-Williams, Trustee Elect thanked Trustee Scott Martin and Trustee Mike Martin for their diligent service to the board on behalf of the residents of Ypsilanti Township.

CONSENT AGENDA

A. MINUTES OF THE NOVEMBER 1, 2016 WORK SESSION AND REGULAR MEETING

B. STATEMENTS AND CHECKS

- 1. STATEMENTS AND CHECKS FOR NOVEMBER 15, 2016 IN THE AMOUNT OF \$1,099.440.30**
- 2. CHOICE HEALTH CARE DEDUCTIBLE ACH EFT FOR OCTOBER 2016 IN THE AMOUNT OF \$25,357.61**
- 3. CHOICE HEALTH CARE ADMIN FEE FOR SEPTEMBER 2016 IN THE AMOUNT OF \$1,200.00**

C. OCTOBER 2016 TREASURER'S REPORT

**CHARTER TOWNSHIP OF YPSILANTI
NOVEMBER 15, 2016 REGULAR MEETING MINUTES
PAGE 2**

Treasurer Doe made a motion, supported by Trustee S. Martin to approve the Consent Agenda.

The motion carried unanimously.

SUPERVISORS REPORT (given at the work session)

Supervisor Stumbo stated that when you serve on a board with people they become like family. She said she appreciates Scott and Mike and loves them very much.

CLERKS REPORT (given at work session)

TREASURERS REPORT (given at work session)

TRUSTEE REPORT

Trustee Eldridge thanked Diana and Wendy the wives of Trustee Scott Martin and Trustee Mike Martin for sharing their spouses with the Township.

Trustee Scott Martin thanked all the Board members for their support over the years. He said that he wanted to give the new Trustees some advice. Trustee S. Martin said when you have residents in the audience like Ms. Kaiser appreciate it because you don't get them often. He thanked Ms. Kaiser, Jo Ann McCollum, and others that frequently come to board meetings for being the eyes in their neighborhoods and keeping the board updated on what was happening in their neighborhoods. He said he felt in the beginning Ms. Kaiser was probably the one watching but she made him sharpen his pencil and do this job, reading his agenda and minutes prior to getting to the meeting. Trustee Scott Martin stated that working with the fellow Trustees had been tremendous. He said he would miss everyone. Trustee S. Martin stated that Mr. Winters was an above and beyond Attorney and he thanked him.

Trustee Mike Martin stated that Stan Eldridge was always the senior trustee and that he would need to guide the new trustees and keep the board on the straight and narrow. He said it had been a good team and it's been his pleasure for the last 8 years. He said Scott brought a lot to the team when he came on the board. He said that Brenda had been a fine leader and that her vision and Attorney Winters facilitation helped them get through some rough years. He said that Karen was the most tireless speaker he knows and said she does a great job and appreciates what she had done for the township. He said Larry was the quiet rock on the board and had given him great counsel on the board. He said Doug had been tenacious in helping the board over the stormy last 8 years. He said he appreciated all Doug had done for the township. Trustee Mike Martin said it had been a memorable 8 years and thanked the residents of Ypsilanti Township for giving him the opportunity to serve our community. He also thanked Ms. Kaiser for being at every meeting and for her input.

**CHARTER TOWNSHIP OF YPSILANTI
NOVEMBER 15, 2016 REGULAR MEETING MINUTES
PAGE 3**

OLD BUSINESS

A motion was made by Treasurer Doe, supported by Trustee S. Martin to remove from table Resolution 2016-44 Supervisor's Wage

S. Eldridge:	Yes	S. Martin:	Yes	Stumbo:	Yes
Lovejoy Roe:	Yes	Doe:	Yes	M. Martin:	Yes

1. RESOLUTION 2016-44 SUPERVISOR'S WAGE

A motion was made by Clerk Lovejoy Roe, supported by Treasurer Doe to approve Resolution 2016-44 Supervisor's Wage (see attached).

The motion carried unanimously.

A motion was made by Treasurer Doe, supported by Trustee S. Martin to remove from table Resolution 2016-45, Clerk's Wage

S. Eldridge:	Yes	S. Martin:	Yes	Stumbo:	Yes
Lovejoy Roe:	Yes	Doe:	Yes	M. Martin:	Yes

2. RESOLUTION 2016-45, CLERK'S WAGE

A motion was made by Treasurer Doe, supported by Trustee S. Martin to approve Resolution 2016-45 Clerk's Wage (see attached).

The motion carried unanimously.

A motion was made by Clerk Lovejoy Roe, supported by Trustee M. Martin to remove from table Resolution 2016-46, Treasurer's Wage

S. Eldridge:	Yes	S. Martin:	Yes	Stumbo:	Yes
Lovejoy Roe:	Yes	Doe:	Yes	M. Martin:	Yes

3. RESOLUTION 2016-46, TREASURER'S WAGE

A motion was made by Clerk Lovejoy Roe, supported by Trustee S. Martin to approve Resolution 2016-46 (see attached).

The motion carried unanimously.

NEW BUSINESS

1. BUDGET AMENDMENT #16

**CHARTER TOWNSHIP OF YPSILANTI
NOVEMBER 15, 2016 REGULAR MEETING MINUTES
PAGE 4**

A motion was made by Clerk Lovejoy Roe, supported by Treasurer Doe to approve Budget Amendment #16 (see attached).

The motion carried unanimously.

2. RESOLUTION 2016-57, AUTHORIZING THE DIVISION OF PLATTED LOTS IN THE WASHTENAW CLUBVIEW SUBDIVISION

A motion was made by Clerk Lovejoy Roe, supported by Treasurer Doe to approve Resolution 2016-57, Authorizing the Division of Platted Lots in the Washtenaw Clubview Subdivision (see attached).

The motion carried unanimously.

3. RESOLUTION 2016-59, AUTHORIZING THE ROAD NAME CHANGE OF RILEY COURT TO HARVEY PLACE

A motion was made by Clerk Lovejoy Roe, supported by Treasurer Doe to approve Resolution 2016-59, Authorizing the Road Name Change of Riley Court to Harvey Place (see attached).

Mr. Beal stated he was the owner of the property and he was going through with rebranding and making improvements to the property and wanted to change the name to Harvey Court Apartments and would like the street to be changed to Harvey Place. He said he changed the sign and would be glad to change the street sign to Harvey Place.

The motion carried unanimously

4. REQUEST FOR AUTHORIZATION TO SIGN PURCHASE AGREEMENT WITH DTE FOR THE INSTALLATION OF TWO (2) OVERHEAD FED 135 WATT AUTOBAHN LED FIXTURES WITH GRAY HOUSINGS MOUNTED ON 17'6" STEEL ARMS ATTACHED TO TWO NEW WOOD POLES IN THE AMOUNT OF \$4,174.42 TO BE LOCATED AT THE BUS STOP ON ECORSE RD BETWEEN REDWOOD AVENUE AND ROSEWOOD AVENUE BUDGETED IN LINE ITEM #101-956-000-926-050

A motion was made by Clerk Lovejoy Roe, supported by Trustee S. Martin to Approve Request for Authorization to Sign Purchase Agreement with DTE for the Installation of Two (2) Overhead FED 135 Watt Autobahn LED Fixtures with Gray Housings Mounted on 17'6" Steel Arms Attached to two New Wood Poles in the Amount of \$4,174.42 to be Located at the Bus Stop on Ecorse Rd. Between Redwood Avenue and Rosewood Avenue Budgeted in Line Item #101-956-000-926-050 (see attached)

The motion carried unanimously.

**CHARTER TOWNSHIP OF YPSILANTI
NOVEMBER 15, 2016 REGULAR MEETING MINUTES
PAGE 5**

- 5. REQUEST FOR AUTHORIZATION TO SIGN THE PURCHASE AGREEMENT WITH DTE FOR THE INSTALLATION OF ONE (1) OVERHEAD FED 135 WATT AUTOBAHN LED FIXTURE WITH GRAY HOUSINGS MOUNTED ON 17'6" STEEL ARM ATTACHED TO A NEW WOOD POLE IN THE AMOUNT OF \$1,988.61 BUDGETED IN LINE ITEM #101-956-000-926-050**

A motion was made by Clerk Lovejoy Roe, supported by Treasurer Doe to Approve Request for Authorization to Sign the Purchase Agreement with DTE for the Installation of One (1) Overhead FED 135 Watt Autobahn Led Fixture with Gray Housings Mounted on 17'6" Steel Arm Attached to a New Wood Pole in the Amount of \$1,988.61 Budgeted in Line Item #101-956-000-926-050 (see attached)

The motion carried unanimously.

Trustee Mike Martin thanked Mike Radzik, Jeff Allen, Joe Lawson, Travis McDugald, Nancy Wrybkowski, Lisa Garrett for all the work they have done for the township.

AUTHORIZATION AND BIDS

- 1. REQUEST OF ANGELA VERGES, RECREATION SUPERINTENDENT TO SEEK BIDS FOR THE PRINTING OF THE "DISCOVER YPSILANTI TOWNSHIP RECREATION GUIDE"**

A motion was made by Clerk Lovejoy Roe, supported by Treasurer Doe to Approve Request of Angela Verges, Recreation Superintendent to Seek Bids for the Printing of the "Discover Ypsilanti Township Recreation Guide".

The motion carried unanimously.

- 2. REQUEST OF TRAVIS MCDUGALD, IS MANAGER TO ACCEPT THE LOW PROPOSAL FROM CLEARRATE COMMUNICATION TO PROVIDE TELEPHONE UTILITY SERVICES IN THE AMOUNT OF \$618.00 PER MONTH AND TO AUTHORIZE SIGNING OF NECESSARY DOCUMENTS CONTINGENT UPON ATTORNEY REVIEW**

A motion was made by Clerk Lovejoy Roe , supported by Treasurer Doe to Approve Request of Travis McDugald, IS Manager to Accept the Low Proposal from Clearrate Communication to Provide Telephone Utility Services in the Amount of \$618.00 per month and to Authorize Signing of Necessary Documents Contingent upon Attorney Review.

The motion carried unanimously.

- 3. REQUEST OF TRAVIS MCDUGALD, IS MANAGER TO ACCEPT THE LOW PROPOSAL OBTAINED THROUGH THE MICHIGAN INTERGOVENMENTAL TRADE NETWORK (MITN) FOR THE PURCHASE OF WINDOWS SERVER 2016**

**CHARTER TOWNSHIP OF YPSILANTI
NOVEMBER 15, 2016 REGULAR MEETING MINUTES
PAGE 6**

**LICENSING FROM CIVITAS IT IN THE AMOUNT OF \$26,043.68 BUDGETED IN
LINE ITEM #101-266-000-977-001**

A motion was made by Trustee S. Martin, supported by Trustee M. Martin to Approve Request of Travis McDugald, IS Manager to Accept the Low Proposal Obtained Through the Michigan Intergovernmental Trade Network (MITN) for the Purchase of Windows Server 2016 Licensing from Civitas IT in the Amount of \$26,043.68 Budgeted in Line Item #101-266-000-977-001.

The motion carried unanimously.

A motion was made by Treasurer Doe, supported by Trustee S. Martin to Adjourn.

The motion carried unanimously.

The meeting was adjourned at approximately 8:32p.m.

Respectfully Submitted,

Brenda L. Stumbo, Supervisor
Charter Township of Ypsilanti

Karen Lovejoy Roe, Clerk
Charter Township of Ypsilanti

CHARTER TOWNSHIP OF YPSILANTI
RESOLUTION NO. 2016-44
ESTABLISH TOWNSHIP SUPERVISOR'S SALARY

WHEREAS according to MCL 41.95(3), in a township that does not hold an annual meeting, the salary for elected officials shall be determined by the township board; and

WHEREAS the salary for the office of Supervisor was decreased in 2010 by 3% from the 2009 total salary and remained the same in 2011, 2012 and 2013 at \$73,653.80 annually; and

WHEREAS in 2014, it was restored to the 2009 total salary of \$75,931.75; and

WHEREAS in 2015 and 2016, a 1.5% increase was given, the same as AFSCME, Teamsters and non-union employees; and

WHEREAS per their contracts, all AFSCME and Teamster employees will receive a 1.5% increase in 2017; and

WHEREAS it is proposed that non-union employees also receive this increase,

NOW THEREFORE BE IT RESOLVED that the salary for the office of Supervisor shall receive a 1.5% increase from \$78,226.79 to \$79,400.19; and

BE IT FURTHER RESOLVED that elected officials' wages will be paid bi-monthly per our auditor's recommendation.

I, Karen Lovejoy Roe, Clerk of the Charter Township of Ypsilanti, County of Washtenaw, State of Michigan hereby certify the above resolution is a true and exact copy of Resolution No. 2016-44 approved by the Charter Township of Ypsilanti, Board of Trustees assembled at a Regular Meeting held on November 15, 2016.

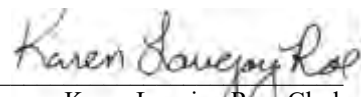

Karen Lovejoy Roe, Clerk
Charter Township of Ypsilanti

CHARTER TOWNSHIP OF YPSILANTI
RESOLUTION NO. 2016-45
ESTABLISH TOWNSHIP CLERK'S SALARY

WHEREAS according to MCL 41.95(3), in a township that does not hold an annual meeting, the salary for elected officials shall be determined by the township board; and

WHEREAS the salary for the office of Clerk was decreased in 2010 by 3% from the 2009 total salary and remained the same in 2011, 2012 and 2013 at \$73,653.80 annually; and

WHEREAS in 2014, it was restored to the 2009 total salary of \$75,931.75; and

WHEREAS in 2015 and 2016, a 1.5% increase was given, the same as AFSCME, Teamsters and non-union employees; and

WHEREAS per their contracts, all AFSCME and Teamster employees will receive a 1.5% increase in 2017; and

WHEREAS it is proposed that non-union employees also receive this increase,

NOW THEREFORE BE IT RESOLVED that the salary for the office of Clerk shall receive a 1.5% increase from \$78,226.79 to \$79,400.19; and

BE IT FURTHER RESOLVED that elected officials' wages will be paid bi-monthly per our auditor's recommendation.

I, Karen Lovejoy Roe, Clerk of the Charter Township of Ypsilanti, County of Washtenaw, State of Michigan hereby certify the above resolution is a true and exact copy of Resolution No. 2016-45 approved by the Charter Township of Ypsilanti, Board of Trustees assembled at a Regular Meeting held on November 15, 2016.

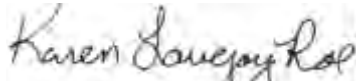

Karen Lovejoy Roe, Clerk
Charter Township of Ypsilanti

CHARTER TOWNSHIP OF YPSILANTI
RESOLUTION NO. 2016-46
ESTABLISH TOWNSHIP TREASURER'S SALARY

WHEREAS according to MCL 41.95(3), in a township that does not hold an annual meeting, the salary for elected officials shall be determined by the township board; and

WHEREAS the salary for the office of Treasurer was decreased in 2010 by 3% from the 2009 total salary and remained the same in 2011, 2012 and 2013 at \$73,653.80 annually; and

WHEREAS in 2014, it was restored to the 2009 total salary of \$75,931.75; and

WHEREAS in 2015 and 2016, a 1.5% increase was given, the same as AFSCME, Teamsters and non-union employees; and

WHEREAS per their contracts, all AFSCME and Teamster employees will receive a 1.5% increase in 2017; and

WHEREAS it is proposed that non-union employees also receive this increase,

NOW THEREFORE BE IT RESOLVED that the salary for the office of Treasurer shall receive a 1.5% increase from \$78,226.79 to \$79,400.19; and

BE IT FURTHER RESOLVED that elected officials' wages will be paid bi-monthly per our auditor's recommendation.

I, Karen Lovejoy Roe, Clerk of the Charter Township of Ypsilanti, County of Washtenaw, State of Michigan hereby certify the above resolution is a true and exact copy of Resolution No. 2016-46 approved by the Charter Township of Ypsilanti, Board of Trustees assembled at a Regular Meeting held on November 15, 2016.

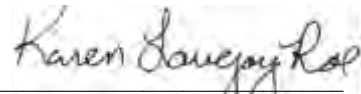

Karen Lovejoy Roe, Clerk
Charter Township of Ypsilanti

**CHARTER TOWNSHIP OF YPSILANTI
2016 BUDGET AMENDMENT #16**

November 15 , 2016

101 - GENERAL OPERATIONS FUND

Total Increase \$31,288.00

Request to increase budget for staff overtime in the Clerk's Department due to the General Election and EMU passports issued after hours. This will be funded by increasing the passport revenue in General Fund.

Revenues:	Passport	101-000-000-626.633	\$4,600.00
		Net Revenues	<u><u>\$4,600.00</u></u>
Expenditures:	Reg Overtime	101-215-000-709.000	\$4,600.00
		Net Expenditures	<u><u>\$4,600.00</u></u>

Request to increase budget for health care deductions for the human resource department, only 70% of total was originally budget. This will be funded by an appropriation of prior year fund balance.

Revenues:	Prior Year Fund Balance	101-000-000-699.000	\$2,650.00
		Net Revenues	<u><u>\$2,650.00</u></u>
Expenditures:	Health Care Deduction	101-227-000-719.020	\$2,650.00
		Net Expenditures	<u><u>\$2,650.00</u></u>

Request to increase budget for health care for residential services administration department, due to a change in health care coverage. This will be funded by an appropriation of prior year fund balance.

Revenues:	Prior Year Fund Balance	101-000-000-699.000	\$2,875.00
		Net Revenues	<u><u>\$2,875.00</u></u>
Expenditures:	Health Care	101-762-000-719.000	\$2,875.00
		Net Expenditures	<u><u>\$2,875.00</u></u>

Request to increase budget for postage. The cost for postage was higher than anticipated due to the postcards sent for a new millage request and for return postage for absentee ballot mailing for the general election. This will be funded by an appropriation of prior year fund balance.

Revenues:	Prior Year Fund Balance	101-000-000-699.000	\$15,000.00
		Net Revenues	<u><u>\$15,000.00</u></u>
Expenditures:	Postage	101-267-000-730.000	\$15,000.00
		Net Expenditures	<u><u>\$15,000.00</u></u>

**CHARTER TOWNSHIP OF YPSILANTI
2016 BUDGET AMENDMENT #16**

November 15 , 2016

101 - GENERAL OPERATIONS FUND - CONTINUED

Request to increase budget for 2 new streetlights one to be located at the bus stop at Ecorse Road between Redwood Avenue & Rosewood Avenue in the amount of \$4,174.42 and one to be located at the curve on S Grove Street just east of Harry Street in the amount of \$1,988.61. This will be funded by an appropriation of prior year fund balance.

Revenues:	Prior Year Fund Balance	101-000-000-699.000	\$6,163.00
		Net Revenues	\$6,163.00
Expenditures:	Street Light - Construction	101-956-000-926.050	\$6,163.00
		Net Expenditures	\$6,163.00

212 - BIKE, SIDEWALK, RECREATION, ROADS, & GENERAL FUND	Total Increase \$27,878.00
--	-----------------------------------

Request to increase the budget for the tennis & pickle ball court grant project at Ford Lake Park. The Township awarded the bid for higher than the estimated budget for the project. This will be funded by an Appropriation of Prior Year Fund Balance.

Revenues:	Prior Year Appropriation	212-000-000-699.000	\$16,787.00
		Net Revenues	\$16,787.00
Expenditures:	Capital Outlay - Recreation	212-970-000-997.001	\$16,878.00
		Net Expenditures	\$16,878.00

Request to increase the budget for the Apppleridge Park project. The bid for the sidewalk surrounding the park was higher than anticipated. The State gave us an additional \$8,000 in grant revenue and we need to match the additional \$3,000. This will be funded by addition to grant revenue of \$8,000 and \$3,000 appropriated from prior year fund balance.

Revenues:	MI State Grant - Recreation/Parks	212-000-000-569.026	\$8,000.00
	Prior Year Appropriation	212-000-000-699.000	\$3,000.00
		Net Revenues	\$8,000.00
Expenditures:	Park Improvements	212-970-000-975-795	\$11,000.00
		Net Expenditures	\$11,000.00

Motion to Amend the 2016 Budget (#16):

Move to increase the General Fund budget by \$31,288 to \$8,875,245 and approve the department line item changes as outlined.

Move to increase the Bike, Sidewalk, Recreation, Roads & General Fund budget by \$27,878 to \$1,818,314 and approve the department line item changes as outlined.

Resolution No. 2016-57

Resolution Authorizing the Division of Platted Lots in Washtenaw ClubView Subdivision

WHEREAS, the owners of a portion of Lots 1, 2 and 3 of Washtenaw ClubView Subdivision have made a request to change lot boundaries as previously approved and recorded; and

WHEREAS, Township ordinance no. 2000-243, Article IX, Section 11.01 states that "Upon the filing of a petition, by the owner or owners of all interest therein, with the Township Board, the platted lots, outlot, or parcels of land in existing recorded plats may be partitioned or divided upon resolution of the Township Board into not more than four (4) parts, each of which shall, in regard to width, depth and area, conform to the terms and provisions of the Charter Township of Ypsilanti Zoning Ordinance, as amended; and

WHEREAS, the Township Planning Director has reviewed the division and confirmed that the resulting parcels meet the minimum requirements for lot size and road frontage as set forth by Section 2000 of the Township Zoning Ordinance.

THEREFORE, BE IT RESOLVED, that the revised property descriptions are approved as follows:

LEGAL DESCRIPTION: ALL OF LOT 3 AND PART OF LOT 1 AND LOT 2 WASHTENAW CLUB VIEW SUBDIVISION

LOT 3 OF "WASHTENAW CLUB VIEW SUBDIVISION", ACCORDING TO THE PLAT THEREOF, AS RECORDED IN WASHTENAW COUNTY RECORDS ALSO THE FOLLOWING DESCRIBED PORTION OF LOTS 1 AND 2 OF SAID SUBDIVISION BEGINNING AT THE NORTHWEST CORNER OF SAID LOT 3; THENCE S00°39'37"W 130.03 FEET ALONG THE WESTERLY LINE OF SAID LOT 3 TO THE SOUTH, U.E OF THE NORTH 130.00 FEET OF SAID LOT 3; THENCE CONTINUING S00°39'37"W 4.15 FEET ALONG SAID WESTERLY LINE; THENCE N76.36'10"W 41.00 FEET; THENCE N00°39'37"E 126.00 FEET TO A POINT ON THE NORTH LINE OF SAID LOT 1; THENCE S88°06'18"E 40.00 FEET ALONG THE NORTHEASTLY LINE OF SAID LOTS 1 AND 2 TO THE PLACE OF BEGINNING. CONTAINING 0.30 ACRES OF LAND, MORE OR LESS, BEING SUBJECT TO EASEMENTS AND RESTRICTIONS OF RECORD, IF ANY.

LEGAL DESCRIPTION: PART OF LOT 1 AND LOT 2 WASHTENAW CLUB VIEW SUBDIVISION

PART OF LOTS 1 AND 2 OF "WASHTENAW CLUB VIEW SUBDIVISION" ACCORDING TO THE PLAT THEREOF, AS RECORDED IN WASHTENAW COUNTY RECORDS, BEING DESCRIBED AS FOLLOWS: COMMENCING AT THE NORTHEAST CORNER OF SAID LOT 2; THENCE N88°06'18"W 40.00 FEET ALONG THE NORTHERLY LINE OF SAID LOTS 1 AND 2 FOR A PLACE OF BEGINNING; THENCE S00°39'37"W 126.00 FEET; THENCE N76°36'10"W 139.93 FEET TO A POINT ON THE WESTERLY LINE OF SAID LOT 1; THENCE NON-TANGENTIALLY 105.80 FEET ALONG SAID WESTERLY LINE AND THE ARC OF A 158.01 FOOT RADIUS CIRCULAR CURVE TO THE RIGHT THROUGH A CENTRAL ANGLE OF 38°21'50" AND HAVING A CHORD BEARING N17°10'05"W 103.83 FEET TO THE NORTHWEST CORNER OF SAID LOT 1; THENCE NON-TANGENTIALLY S88°06'18"E 168.52 FEET ALONG THE NORTHERLY LINE OF SAID LOTS 1 AND 2 TO THE PLACE OF BEGINNING, CONTAINING 0.40 ACRES OF LAND, MORE OR LESS, BEING SUBJECT TO EASEMENTS AND RESTRICTIONS OF RECORD, IF ANY.

I, Karen Lovejoy Roe, Clerk of the Charter Township of Ypsilanti, County of Washtenaw, State of Michigan hereby certify the above resolution is a true and exact copy of Resolution No. 2016-47 approved by the Charter Township of Ypsilanti, Board of Trustees assembled at a Regular Meeting held on November 15, 2016.

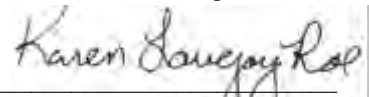

Karen Lovejoy Roe, Clerk
Charter Township of Ypsilanti

RESOLUTION NO. 2016-59

A Resolution Changing the Road Name of Riley Court to Harvey Place

WHEREAS, the Charter Township of Ypsilanti Board of Trustees, on behalf of the owner of Riley Court, changing the name of Riley Court to Harvey Place; and

WHEREAS, the Charter Township of Ypsilanti will request street signs to be posted;

NOW, THEREFORE, BE IT RESOLVED that the name of Riley Court will be changed to Harvey Place.

BE IT FURTHER RESOLVED that Ypsilanti Township Clerk Karen Lovejoy Roe shall record a certified copy of this resolution with the Washtenaw County Register of Deeds and send a copy to the State Treasurer as required by law.

I, Karen Lovejoy Roe, Clerk of the Charter Township of Ypsilanti, County of Washtenaw, State of Michigan hereby certify the above resolution is a true and exact copy of Resolution No. 2016-59 approved by the Charter Township of Ypsilanti, Board of Trustees assembled at a Regular Meeting held on November 15, 2016.



Karen Lovejoy Roe, Clerk

Charter Township of Ypsilanti

Exhibit A to Master Agreement

Purchase Agreement

This Purchase Agreement (this "Agreement") is dated as of November 9, 2016 between The Detroit Edison Company ("Company") and Charter Township of Ypsilanti ("Customer").

This Agreement is a "Purchase Agreement" as referenced in the Master Agreement for Municipal Street Lighting dated March 28, 2013 (the "Master Agreement") between Company and Customer. All of the terms of the Master Agreement are incorporated herein by reference. In the event of an inconsistency between this Agreement and the Master Agreement, the terms of this Agreement shall control.

Customer requests the Company to furnish, install, operate and maintain street lighting equipment as set forth below:

1. DTE Work Order Number:	46454788	
	If this is a conversion or replacement, indicate the Work Order Number for current installed equipment: N/A	
2. Location where Equipment will be installed:	At the bus stop on Ecorse Rd between Redwood Ave & Rosewood Ave in Ypsilanti Township, as more fully described on the map attached hereto as <u>Attachment 1</u> .	
3. Total number of lights to be installed:	2	
4. Description of Equipment to be installed (the " <u>Equipment</u> "):	Install 2 overhead fed 135 watt Autobahn LED fixtures with gray housings mounted on 17'-6" steel arms attached to 2 new wood poles.	
5. Estimated Total Annual Lamp Charges	\$330.62	
6. Computation of Contribution in aid of Construction (" <u>CIAC Amount</u> ")	Total estimated construction cost, including labor, materials, and overhead:	\$5,166.28
	Credit for 3 years of lamp charges:	\$991.86
	CIAC Amount (cost minus revenue)	\$4,174.42
7. Payment of CIAC Amount:	Due promptly upon execution of this Agreement	
8. Term of Agreement	5 years. Upon expiration of the initial term, this Agreement shall continue on a month-to-month basis until terminated by mutual written consent of the parties or by either party with thirty (30) days prior written notice to the other party.	
9. Does the requested Customer lighting design meet IESNA recommended practices?	(Check One) <input type="checkbox"/> YES <input checked="" type="checkbox"/> NO If "No", Customer must sign below and acknowledge that the lighting design does not meet IESNA recommended practices <p align="center">Signature: <i>Brenda L. Stumbo / Karen Lovejoy Roe</i></p>	
10. Customer Address for Notices:	Charter Township of Ypsilanti 7200 S Huron River Dr Ypsilanti, MI 48197 Attn: Karen Lovejoy Roe	

11. Special Order Material Terms:

All or a portion of the Equipment consists of special order material: (check one) YES NO

If "Yes" is checked, Customer and Company agree to the following additional terms.

A. Customer acknowledges that all or a portion of the Equipment is special order materials ("SOM") and not Company's standard stock. Customer will purchase and stock replacement SOM and spare parts. When replacement equipment or spare parts are installed from Customer's inventory, the Company will credit Customer in the amount of the then current material cost of Company standard street lighting equipment.

B. Customer will maintain an initial inventory of at least **N/A** posts and **N/A** luminaires and any other materials agreed to by Company and Customer, and will replenish the stock as the same are drawn from inventory. Costs of initial inventory are included in this Agreement. The Customer agrees to work with the Company to adjust inventory levels from time to time to correspond to actual replacement material needs. If Customer fails to maintain the required inventory, Company, after 30 days' notice to Customer, may (but is not required to) order replacement SOM and Customer will reimburse Company for such costs. Customer's acknowledges that failure to maintain required inventory could result in extended outages due to SOM lead times.

C. The inventory will be stored at _____.
Access to the Customers inventory site must be provided between the hours of 9:00 am to 4:00 pm, Monday through Friday with the exceptions of federal Holidays. Customer shall name an authorized representative to contact regarding inventory: levels, access, usage, transactions, and provide the following contact information to the Company:

Name: _____ Title: _____

Phone Number: _____ Email: _____

The Customer will notify the Company of any changes in the Authorized Customer Representative. The Customer must comply with SOM manufacturer's recommended inventory storage guidelines and practices. Damaged SOM will not be installed by the Company.

D. In the event that SOM is damaged by a third party, the Company may (but is not required to) pursue a damage claim against such third party for collection of all labor and stock replacement value associated with the damage claim. Company will promptly notify Customer as to whether Company will pursue such claim.

E. In the event that SOM becomes obsolete or no longer manufactured, the Customer will be allowed to select new alternate SOM that is compatible with the Company's existing infrastructure.

F. Should the Customer experience excessive LED equipment failures, not supported by LED manufacturer warrantees, the Company will replace the LED equipment with other Company supported Solid State or High Intensity Discharge luminaires at the Company's discretion. The full cost to complete these replacements to standard street lighting equipment will be the responsibility of the Customer.

12. Experimental Emerging Lighting Technology ("EELT") Terms:

All or a portion of the Equipment consists of EELT: (check one) YES NO

If "Yes" is checked, Customer and Company agree to the following additional terms.

A. The annual billing lamp charges for the EELT equipment has been calculated by the Company are based upon the estimated energy and maintenance cost expected with the Customer's specific pilot project EELT equipment. .

B. Upon the approval of any future MPSC Option I tariff for EELT street lighting equipment, the approved rate schedules will automatically apply for service continuation to the Customer under Option 1 Municipal Street Lighting Rate, as approved by the MPSC. The terms of this paragraph B replace in its entirety Section 7 of the Master Agreement with respect to any EELT equipment purchased under this Agreement.

Company and Customer have executed this Purchase Agreement as of the date first written above.

Company:

The Detroit Edison Company

By: _____

Name: _____

Title: _____

Customer:

Charter Township of Ypsilanti

By: Brenda L. Stumbo / Karen Lovsjou Roc

Name: Brenda L. Stumbo / Karen Lovsjou Roc

Title: Supervisor / Clerk

November 16, 2016

Attachment 1 to Purchase Agreement

Map of Location

[To be attached]

**YPSILANTI TOWNSHIP
2 NEW OVERHEAD STREET LIGHTS
EXHIBIT "B"**

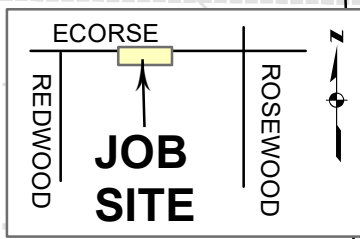

OAKLAWN AVE

ECORSE RD

ROSEWOOD A

PINEWOOD ST

WL 1: 201174-268764
 IN: 35 4 PINE
 IN: SSS-DET 282
 IN: MULTIPLE LED 135 LLT COBRA - 7 PIN - GRAY
 IN: OH CODE S48
 IN: PCLL
 L 135 AFU730 -- 9000 YPSIL -- A230 -- 701
 IN: DET 605B
 IN: DET 605B

WL 2: 201160-268846
 IN: 35 4 PINE
 IN: SSS-DET 282
 IN: MULTIPLE LED 135 LLT COBRA - 7 PIN - GRAY
 IN: OH CODE S48
 IN: PCLL
 L 135 AFU731 -- 9000 YPSIL -- A230 -- 701
 IN: DET 605D

WL 3:
 IN: 6A6D

WL 4:
 IN: DET 605D

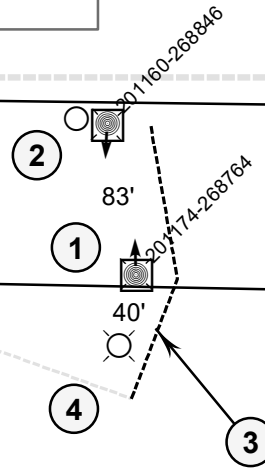

DTE Electric - Distribution Engineering and Planning									
Service Planner		Work Order Description							
O'Donnell, Michael W		SL - NBUS - 2 OH - Ecorse Rd btwn Redwood & Rosewood - Ypsilanti Twp							
Phone		Work Order #	GIS-DSN	COH	CUL	CUG	PLC		
586.412.4771		46458323							
Supervisor		Circuit #1			Circuit #2		PH		SCMAT
Brian R Kinnick		EMRCK2922							
Phone		Service Center	Worksite City			Worksite Twp		County	
734.397.4024		ANN	YPSILANTI			YPSILANTI		Washtenaw	
Planning Engineer		JU Work to be Performed					JU		RSD
		JU Company		Contact	Email		Phone		
		JU Company		Contact	Email		Phone		
Phone		CUE Number	Ver	Plot Date	Scale	Town	Range	Section	Qtr
		682719	1	11/8/2016		03S	07E	10	

Exhibit A to Master Agreement

Purchase Agreement

This Purchase Agreement (this "Agreement") is dated as of November 10, 2016 between The Detroit Edison Company ("Company") and Charter Township of Ypsilanti ("Customer").

This Agreement is a "Purchase Agreement" as referenced in the Master Agreement for Municipal Street Lighting dated March 28, 2013 (the "Master Agreement") between Company and Customer. All of the terms of the Master Agreement are incorporated herein by reference. In the event of an inconsistency between this Agreement and the Master Agreement, the terms of this Agreement shall control.

Customer requests the Company to furnish, install, operate and maintain street lighting equipment as set forth below:

1. DTE Work Order Number:	46272814 If this is a conversion or replacement, indicate the Work Order Number for current installed equipment: N/A	
2. Location where Equipment will be installed:	At the curve on S Grove St just east of Harry St in Ypsilanti Township, as more fully described on the map attached hereto as <u>Attachment 1</u> .	
3. Total number of lights to be installed:	1	
4. Description of Equipment to be installed (the " <u>Equipment</u> "):	Install (1) overhead fed 135 watt Autobahn LED fixture with gray housing mounted on a 17'-6" steel arm attached to a new wood pole.	
5. Estimated Total Annual Lamp Charges	\$165.31	
6. Computation of Contribution in aid of Construction (" <u>CIAC Amount</u> ")	Total estimated construction cost, including labor, materials, and overhead:	\$2,484.54
	Credit for 3 years of lamp charges:	\$495.93
	CIAC Amount (cost minus revenue)	\$1,988.61
7. Payment of CIAC Amount:	Due promptly upon execution of this Agreement	
8. Term of Agreement	5 years. Upon expiration of the initial term, this Agreement shall continue on a month-to-month basis until terminated by mutual written consent of the parties or by either party with thirty (30) days prior written notice to the other party.	
9. Does the requested Customer lighting design meet IESNA recommended practices?	(Check One) <input type="checkbox"/> YES <input checked="" type="checkbox"/> NO If "No", Customer must sign below and acknowledge that the lighting design does not meet IESNA recommended practices Signature: <i>Brenda L. Stumbo / Karen Lovejoy Roe</i>	
10. Customer Address for Notices:	Charter Township of Ypsilanti 7200 S Huron River Dr Ypsilanti, MI 48197 Attn: Karen Lovejoy Roe	

11. Special Order Material Terms:

All or a portion of the Equipment consists of special order material: (check one) YES NO

If "Yes" is checked, Customer and Company agree to the following additional terms.

A. Customer acknowledges that all or a portion of the Equipment is special order materials ("SOM") and not Company's standard stock. Customer will purchase and stock replacement SOM and spare parts. When replacement equipment or spare parts are installed from Customer's inventory, the Company will credit Customer in the amount of the then current material cost of Company standard street lighting equipment.

B. Customer will maintain an initial inventory of at least **N/A** posts and **N/A** luminaires and any other materials agreed to by Company and Customer, and will replenish the stock as the same are drawn from inventory. Costs of initial inventory are included in this Agreement. The Customer agrees to work with the Company to adjust inventory levels from time to time to correspond to actual replacement material needs. If Customer fails to maintain the required inventory, Company, after 30 days' notice to Customer, may (but is not required to) order replacement SOM and Customer will reimburse Company for such costs. Customer's acknowledges that failure to maintain required inventory could result in extended outages due to SOM lead times.

C. The inventory will be stored at _____.
Access to the Customers inventory site must be provided between the hours of 9:00 am to 4:00 pm, Monday through Friday with the exceptions of federal Holidays. Customer shall name an authorized representative to contact regarding inventory: levels, access, usage, transactions, and provide the following contact information to the Company:

Name: _____ Title: _____

Phone Number: _____ Email: _____

The Customer will notify the Company of any changes in the Authorized Customer Representative. The Customer must comply with SOM manufacturer's recommended inventory storage guidelines and practices. Damaged SOM will not be installed by the Company.

D. In the event that SOM is damaged by a third party, the Company may (but is not required to) pursue a damage claim against such third party for collection of all labor and stock replacement value associated with the damage claim. Company will promptly notify Customer as to whether Company will pursue such claim.

E. In the event that SOM becomes obsolete or no longer manufactured, the Customer will be allowed to select new alternate SOM that is compatible with the Company's existing infrastructure.

F. Should the Customer experience excessive LED equipment failures, not supported by LED manufacturer warranties, the Company will replace the LED equipment with other Company supported Solid State or High Intensity Discharge luminaires at the Company's discretion. The full cost to complete these replacements to standard street lighting equipment will be the responsibility of the Customer.

12. Experimental Emerging Lighting Technology ("EELT") Terms:

All or a portion of the Equipment consists of EELT: (check one) YES NO

If "Yes" is checked, Customer and Company agree to the following additional terms.

A. The annual billing lamp charges for the EELT equipment has been calculated by the Company are based upon the estimated energy and maintenance cost expected with the Customer's specific pilot project EELT equipment. .

B. Upon the approval of any future MPSC Option I tariff for EELT street lighting equipment, the approved rate schedules will automatically apply for service continuation to the Customer under Option 1 Municipal Street Lighting Rate, as approved by the MPSC. The terms of this paragraph B replace in its entirety Section 7 of the Master Agreement with respect to any EELT equipment purchased under this Agreement.

Company and Customer have executed this Purchase Agreement as of the date first written above.

Company:

The Detroit Edison Company

By: _____

Name: _____

Title: _____

Customer:

Charter Township of Ypsilanti

By: Brenda L. Stumbo / Karen Lovyby Roe

Name: Brenda L. Stumbo / Karen Lovyby Roe

Title: Supervisor / Clerk

November 16, 2016

Attachment 1 to Purchase Agreement

Map of Location

[To be attached]

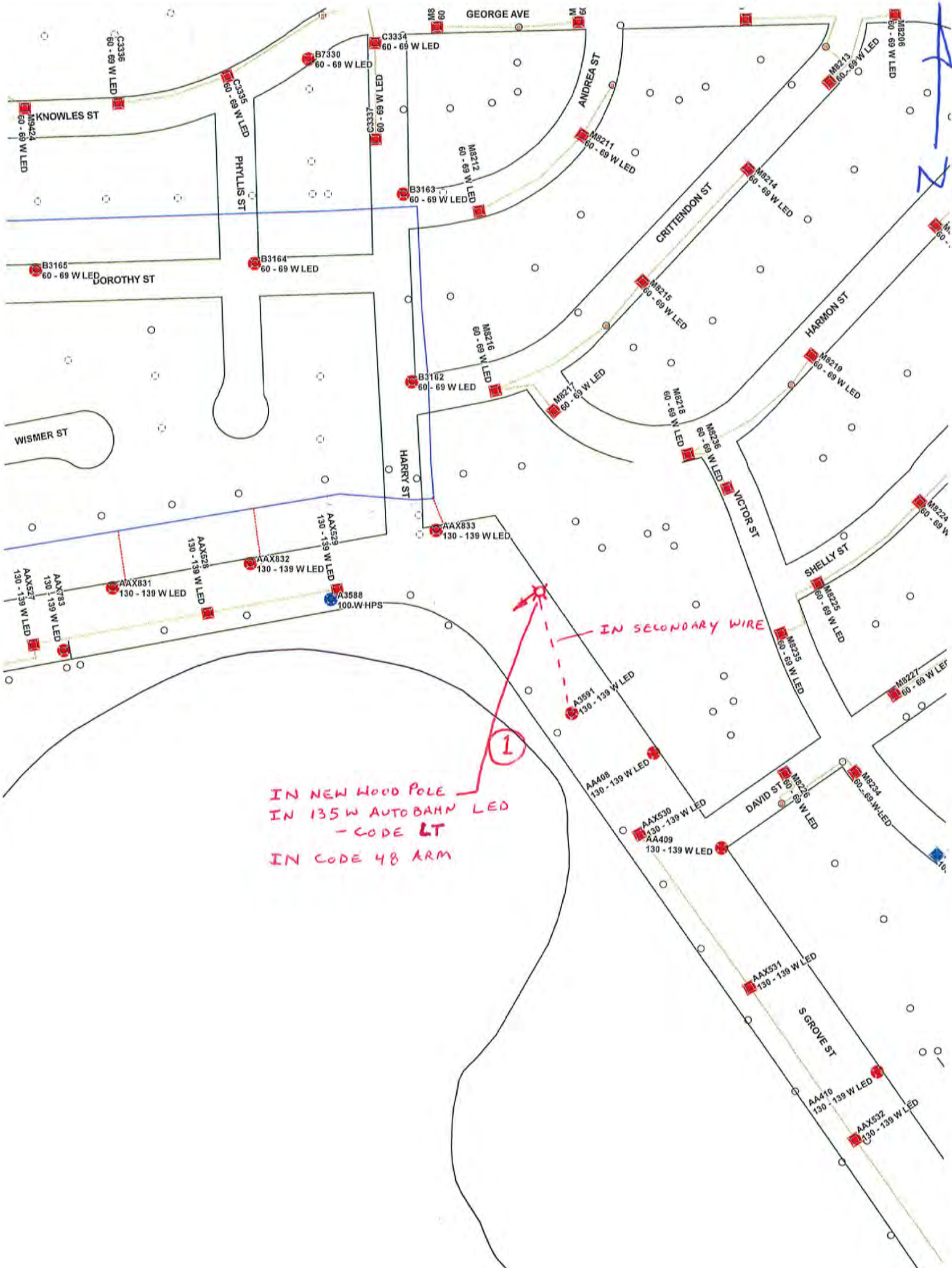

IN SECONDARY WIRE

1

IN NEW HOOD POLE
 IN 135 W AUTOBAHN LED
 - CODE LT
 IN CODE 48 ARM

Supervisor
BRENDA L. STUMBO
Clerk
KAREN LOVEJOY ROE
Treasurer
LARRY J. DOE
Trustees
JEAN HALL CURRIE
STAN ELDRIDGE
MIKE MARTIN
SCOTT MARTIN



**Accounting
Department**

7200 S. Huron River Drive
Ypsilanti, MI 48197
Phone: (734) 484-3702
Fax: (734) 484-5154

Charter Township of Ypsilanti

STATEMENTS AND CHECKS

DECEMBER 6, 2016 BOARD MEETING

ACCOUNTS PAYABLE CHECKS -	\$	167,765.16
HAND CHECKS -	\$	29,258.39
CREDIT CARDS PURCHASES -	\$	1,230.58
GRAND TOTAL -	\$	198,254.13

Check Date	Check	Vendor Name	Amount
Bank AP AP			
11/15/2016	173776	AT & T	3,744.34
11/15/2016	173777	COMCAST CABLE	98.08
11/15/2016	173778	COMCAST CABLE	21.10
11/15/2016	173779	COMCAST CABLE	104.85
11/15/2016	173780	VERIZON WIRELESS	824.91
11/15/2016	173781	WASTE MANAGEMENT	500.00
11/15/2016	173782	WASTE MANAGEMENT	128.75
11/15/2016	173783	WEX BANK	1,170.11
11/15/2016	173784	YPSILANTI COMMUNITY	2,579.38
11/15/2016	173785	DTE ENERGY	14,875.27
11/16/2016	173786	COMCAST CABLE	5,211.60

AP TOTALS:			
Total of 11 Checks:			29,258.39
Less 0 Void Checks:			0.00
Total of 11 Disbursements:			<u>29,258.39</u>

User: mharris

CHECK NUMBERS 173802 - 173887

DB: Ypsilanti-Twp

Check Date	Check	Vendor Name	Amount
Bank AP AP			
12/06/2016	173802	A & R TOTAL CONSTRUCTION, INC.	615.72
12/06/2016	173803	AL WALTERS HEATING AND COOLING	8,053.00
12/06/2016	173804	ALL YEAR TREE SERVICE	300.00
12/06/2016	173805	ALLGRAPHICS CORPORATION	326.40
12/06/2016	173806	ALLSHRED SERVICES	499.99
12/06/2016	173807	ANN ARBOR CLEANING SUPPLY	202.39
12/06/2016	173808	APEX SOFTWARE	1,850.00
12/06/2016	173809	ASSOCIATED FENCE	250.00
12/06/2016	173810	AUTO VALUE YPSILANTI	64.69
12/06/2016	173811	B/C CONTRACTORS, INC.	685.00
12/06/2016	173812	BRANDON SLAVEN	150.00
12/06/2016	173813	BRIDGEWAY POWER	200.00
12/06/2016	173814	BS & A SOFTWARE	17,978.00
12/06/2016	173815	CAROLYN WEINS	427.00
12/06/2016	173816	CDW GOVERNMENT INC	1,679.00
12/06/2016	173817	CINCINNATI TIME SYSTEMS	746.45
12/06/2016	173818	CLOVERDALE EQUIPMENT, CO.	944.00
12/06/2016	173819	CONGDON'S	221.22
12/06/2016	173820	DETROIT REGION AEROTROPOLIS	15,000.00
12/06/2016	173821	DTE ENERGY COMPANY -	4,174.42
12/06/2016	173822	DTE ENERGY COMPANY -	1,988.51
12/06/2016	173823	EMERGENT HEALTH PARTNERS	6,073.99
12/06/2016	173824	FASTENAL	22.89
12/06/2016	173825	FEDERAL EXPRESS CORPORATION	207.26
12/06/2016	173826	FIBER LINK	299.25
12/06/2016	173827	FIRE SERVICE MANAGEMENT	429.29
12/06/2016	173828	FONDRIEST ENVIRONMENTAL, INC	110.86
12/06/2016	173829	GORDON FOOD SERVICE INC.	19.66
12/06/2016	173830	GOVERNMENTAL CONSULTANT	2,850.00
12/06/2016	173831	GRAINGER	4,314.60
12/06/2016	173832	GRAPH-X	1,995.00
12/06/2016	173833	GRIFFIN PEST SOLUTIONS	93.00
12/06/2016	173834	HERITAGE-CRYSTAL CLEAN, LLC	150.26
12/06/2016	173835	HOME DEPOT	335.98
12/06/2016	173836	HYDROCHEM	1,230.00
12/06/2016	173837	JOSEPH LAWSON	396.53
12/06/2016	173838	JTW PIPES LLC	750.00
12/06/2016	173839	KAREN LOVEJOY ROE	129.88
12/06/2016	173840	LOOKING GOOD LAWNS	6,143.00
12/06/2016	173841	LUBRICATION ENGINEERS	120.15
12/06/2016	173842	MARK HAMILTON	1,500.00
12/06/2016	173843	MCLAIN AND WINTERS	9,775.00
12/06/2016	173844	MCMASTER-CARR	212.13
12/06/2016	173845	MESSENGER PRINTING	489.50
12/06/2016	173846	MICHIGAN ABILITY PARTNERS	3,262.90
12/06/2016	173847	MICHIGAN LINEN SERVICE, INC.	1,130.77
12/06/2016	173848	MICHIGAN MUNICIPAL LEAGUE	5,000.00
12/06/2016	173849	MICHIGAN STATE FIREMEN'S ASSOC	75.00
12/06/2016	173850	MIRACLE MIDWEST	1,717.00
12/06/2016	173851	NAPA AUTO PARTS	13.59
12/06/2016	173852	NETWORKFLEET, INC	530.60
12/06/2016	173853	OFFICE DEPOT	448.02
12/06/2016	173854	OFFICE EXPRESS	38.99
12/06/2016	173855	PENCHURA, LLC	1,122.28
12/06/2016	173856	PLAYWORLD MIDSTATES	3,036.93
12/06/2016	173857	PLUNKETT COONEY	202.50
12/06/2016	173858	POLO FIELDS EAST LLC	1,100.00
12/06/2016	173859	PRINTING SYSTEMS	30.28
12/06/2016	173860	RENT A WRECK	331.50
12/06/2016	173861	RESIDEX, LLC	2,254.82
12/06/2016	173862	RICHARD ELLSWORTH	150.00
12/06/2016	173863	RICOH USA, INC.	2,535.14
12/06/2016	173864	RKA PETROLEUM	2,715.05
12/06/2016	173865	SAFEGUARD BUSINESS SYSTEMS	533.05
12/06/2016	173866	SAM'S CLUB DIRECT	63.12
12/06/2016	173867	SIGNS BY TOMORROW	555.60
12/06/2016	173868	SITEONE LANDSCAPE SUPPLY, LLC	250.06
12/06/2016	173869	SOUTHERN COMPUTER WAREHOUSE	3,542.95
12/06/2016	173870	SPOK, INC.	348.65
12/06/2016	173871	STANTEC	1,068.75
12/06/2016	173872	STATE OF MICHIGAN##	700.00
12/06/2016	173873	TERMINIX PROCESSING CENTER	50.00
12/06/2016	173874	TERRAFIRMA	86.00
12/06/2016	173875	TODD BARBER	4,150.00
12/06/2016	173876	USCUTTER, INC	77.49
12/06/2016	173877	VERMEER OF MICHIGAN, INC.	1,853.63
12/06/2016	173878	VICKI DEGRAFFINIERE	100.00
12/06/2016	173879	VICTORY LANE	177.10

11/28/2016 02:34 PM
User: mharris
DB: Ypsilanti-Twp

CHECK REGISTER FOR CHARTER TOWNSHIP OF YPSILANTI Page: 2/2
CHECK NUMBERS 173802 - 173887

Check Date	Check	Vendor Name	Amount
12/06/2016	173880	WASHTENAW COUNTY LEGAL NEWS	300.00
12/06/2016	173881	WASHTENAW COUNTY ROAD COMMISSION	1,261.55
12/06/2016	173882	WASHTENAW COUNTY TREASURER#	28,545.00
12/06/2016	173883	WASHTENAW-LIVINGSTON MEDICAL	178.00
12/06/2016	173884	WEINGARTZ	12.99
12/06/2016	173885	YPSILANTI COMMUNITY	2,411.90
12/06/2016	173886	YPSILANTI TWP. TAX COLLECTION	1,719.59
12/06/2016	173887	ZEP SALES & SERVICE	80.34

AP TOTALS:

Total of 86 Checks:	167,765.16
Less 0 Void Checks:	0.00
Total of 86 Disbursements:	<u>167,765.16</u>

11/28/2016 02:58 PM
User: mharris
DB: Ypsilanti-Twp

CHECK REGISTER FOR CHARTER TOWNSHIP OF YPSILANTI
CHECK NUMBERS 11 - 12

Check Date	Check	Vendor Name	Description	Amount
------------	-------	-------------	-------------	--------

Bank CARDS COMERICA COMMERCIAL CARD

11/28/2016	11 (E)	COMERICA BANK	REPLACE WORN CONTROL CABLE ON BOAT	352.64
			OFFICE SUPPLIES	51.54
			GENERAL TOOLS	82.28
			ANTI-VIRUS PROGRAM FOR NEW HP NOTEBOOK	50.21
			PURCHASE OF ONE HP 15" NOTEBOOK FOR FIRE	480.66
			WEBSITE STOCK IMAGES	114.00
			S500 WALL MOUNTS	99.25
				<hr/>
				1,230.58
				<hr/> <hr/>

CARDS TOTALS:

Total of 1 Checks:	1,230.58
Less 0 Void Checks:	0.00
Total of 1 Disbursements:	<hr/>
	1,230.58

ATTORNEY REPORT

GENERAL LEGAL UPDATE

OLD BUSINESS

CHARTER TOWNSHIP OF YPSILANTI

OFFICE OF COMMUNITY STANDARDS

Building Safety • Planning & Zoning • Ordinance Enforcement

Memorandum

To: Board of Trustees
From: Joe Lawson, Planning Director
Date: November 28, 2016
Re: Second Reading: Resolution 2016-58, Ordinance 2016-471 in order to amend zoning ordinance section 201 “Definitions” to include language relating to “Boarding/Rooming Houses” and “Family”

During the regular meeting held on November 1, 2016, the Board of Trustees approved the first reading of resolution 2016-58 relating to proposed ordinance 2016-471 which would amend Ordinance 74 of the Township Zoning code in part to update the definition of a “Rooming House”.

Since the first reading, Attorney McLain and I have had the opportunity to discuss and further consider the proposed language in relation to a number of ongoing enforcement cases. In comparing how the new language would assist in the enforcement of rooming houses within the Township, it was noted that there may be a loop hole in the proposed language.

That being said, staff requests the consideration of the Board to amend the language prior to the second and final reading. The proposed minor changes are outlined below:

Rooming House: A residential building where rooms or suites of rooms are rented, ~~under separate concurrent rental agreements~~ for compensation ~~whether under a written lease or not~~, by arrangement for definite periods, where the renters use common facilities, such as hallways and bathrooms. A rooming house shall not include hotels, motels, apartments, tourist home, one-family dwellings, two and multi-family dwellings or fraternity and sorority houses.

During a review on-going enforcement cases, it was noted that some occupants of rooming houses may be able to bypass the regulation by signing a single rental agreement as opposed to separate concurrent rental agreements. By eliminating this language from the proposed ordinance, would eliminate a loop hole of “separate” agreements versus a single agreement for all occupants.

CHARTER TOWNSHIP OF YPSILANTI

RESOLUTION NO. 2016-58 (In Reference to Ordinance 2016-471)

Amending the Charter Township of Ypsilanti Zoning Code Section 201, Ordinance 74, entitled "Definitions"

Whereas, the Charter Township of Ypsilanti ("Township") Zoning Code currently contains a definition of the term "family" which the Township's Planning Commission has recommended be replaced with a definition of the term which clarifies the precise meaning of the term as it is used within the Township's Zoning Code; and

Whereas, the Township's Zoning Code does not contain a definition of the term "rooming house" and the Township Planning Commission has recommended that a definition of the term be included in the definitions section of the Township Zoning Code to clarify what is meant when the term is used within the Zoning Code; and

Whereas, Township Ordinance 2016-471, repeals the current definition of the term "family" that appears in the Township Zoning Code, and replaces it with a new, updated definition of the word "family" recommended by the Township Planning Commission; and

Whereas, Township Ordinance 2016-471, defines the term "rooming house" as used within the Zoning Code;

Now therefore, be it resolved that Ordinance 2016-471, is hereby adopted by reference.

PROPOSED ORDINANCE 2016-471

An Ordinance Amending Ordinance No. 74, the Township Zoning Code, Regarding Definitions

The Charter Township of Ypsilanti hereby ordains that Ordinance No. 74, **the Ypsilanti Township Zoning Code**, adopted May 18, 1994, shall be amended as follows:

I. **Delete** in its entirety the definition of “family” set forth in section 201 of the Township Zoning Code.

II. **Add** the following new definition:

Family:

1. A single individual or a number of individuals domiciled together whose relationship is of a continuing nontransient, domestic character and who are cooking and living together as a single, nonprofit housekeeping unit, related by the bonds of consanguinity, marriage, or adoption, together with servants of the principal occupants and not more than one (1) additional unrelated person, with all of such individuals being domiciled together as a single, domestic, housekeeping unit in a dwelling.
2. The functional equivalent of the domestic family, that is, persons living together in a dwelling unit whose relationship is of a permanent and distinct character and is the functional equivalent of a domestic family, with a demonstrable and recognizable bond which constitutes the functional equivalent of the bonds which render the domestic family a cohesive unit. This definition shall not include any rooming house, society, club, fraternity, sorority, association, lodge, coterie organization or group whose association is temporary or seasonal in character or nature. For the purposes of enforcement, it is presumed that a functional equivalent of a domestic family is limited to six (6) or fewer persons.

III. Add the following new definition to section 201 of the Zoning Code:

Rooming House:

1. A residential building where rooms or suites of rooms are rented, ~~under separate concurrent rental agreements~~ for compensation ~~whether under a written lease or not~~, by arrangement for definite periods, where the renters use common facilities, such as hallways and bathrooms. A rooming house shall not include

hotels, motels, apartment houses, tourist homes, one-family dwellings, two and multi-family dwellings or fraternity and sorority houses.

Severability

In the event that any one or more sections, provisions, phrases or words of this ordinance shall be found to be invalid by a Court of competent jurisdiction, such holding shall not affect the validity nor the enforceability of the remaining sections, provisions, phrases or words of this Ordinance unless expressly so determined by a Court of competent jurisdiction.

Non Exclusivity

The prohibitions and penalties provided for in this Ordinance shall be in addition to, and not exclusive of, other prohibitions and penalties provided for by other law, ordinance, or rule/regulation.

Publication

This Ordinance shall be published in a newspaper of general circulation as required by law.

Effective date

This Ordinance shall become effective upon publication in a newspaper of general circulation as required by law.

NEW BUSINESS

**CHARTER TOWNSHIP OF YPSILANTI
2016 BUDGET AMENDMENT #17**

December 6, 2016

225 - ENVIRONMENTAL CLEANUP FUND

Total Increase \$25,000.00

Request to increase budget to allow for a transfer to the Hydro Station Fund. This is for the initial draw to dewater Tyler Dam. The Tyler dam can not use Hydro funds. This will be funded by an Appropriation of Prior Year Fund Balance.

Revenues:	Prior Year Fund Balance	225-000-000-699.000	\$25,000.00
		Net Revenues	<u><u>\$25,000.00</u></u>
Expenditures:	Transfer to Hydro Station	225-225-000-968.252	\$25,000.00
		Net Expenditures	<u><u>\$25,000.00</u></u>

252 - HYDRO STATION FUND

Total Increase \$25,000.00

Request to create and increase a new capital expenditure line titled "Capital Outlay - Tyler Dam Project". The contractor is scheduled to begin work dewatering the pond and removing the sluice gate this year. YCUA is coordinating this joint project and will be paying the contractor directly. The Township will reimburse YCUA when invoiced. This will be funded by a transfer of funds from the Environmental Cleanup Fund.

Revenues:	Transfer In: Environmental Cleanup	252-000-000-697.007	\$25,000.00
		Net Revenues	<u><u>\$25,000.00</u></u>
Expenditures:	Capital Outlay - Tyler Dam Project	252-252-000-971.100	\$25,000.00
		Net Expenditures	<u><u>\$25,000.00</u></u>

590 - COMPOST FUND

Total Increase \$16,233.00

Request to increase budget for the cost of emptying the dumpsters at the Compost site and to increase the budget for the related revenue for trash drop off. This will be funded by an increase to the Gate Revenue - drop off fee revenue line.

Revenues:	Gate Revenue - Drop off Fees	590-000-000-650.203	\$16,233.00
		Net Revenues	<u><u>\$16,233.00</u></u>
Expenditures:	Contractual/Rolloff Disposal	590-590-000-804.000	\$16,233.00
		Net Expenditures	<u><u>\$16,233.00</u></u>

Motion to Amend the 2016 Budget (#17):

Move to increase the Environmental Cleanup Fund by \$25,000 to \$97,000 and approve the department line item changes as outlined.

Move to increase the Hydro Fund by \$25,000 to \$581,112 and approve the department line item changes as outlined.

Move to increase the Compost Fund by \$16,233 to \$945,449 and approve the department line item changes as outlined.

November 15th, 2016

The Charter Township of Ypsilanti
7200 South Huron River Drive
Ypsilanti, MI 48197-7007

ATTENTION: Brenda L. Stumbo, Supervisor and
Karen Lovejoy-Roe, Township Clerk

Re: NEXUS Gas Transmission, LLC ("NEXUS")
Tract Number: MI-WA-000.0001-SA-6.1-SPRD4, MI-WA-107.0020, MI-WA-107.0020-TAR-7-250.2,
MI-WA-110.0000, MI-WA-112.0010, MI-WA-119.0040, MI-WA-119.0050, MI-WA-119.0060, MI-WA-
119.0070, MI-WA-122.0000 & MI-WA-127.0000
Tax Parcel ID Number: K-11-24-300-011, K-11-24-300-001, K-11-23-200-001, K-11-13-331-014, K-11-
13-331-015, K-11-13-331-016, K-11-13-331-017, K-11-13-331-001 & PART OF K-11-13-232-002

Dear: Ms. Stumbo and Ms. Lovejoy-Roe,

Nexus Gas Transmission is now in a position to present our offer for the acquisition of a Grant of Easement on your properties referenced above in connection with NEXUS' proposed pipeline project. A copy of the proposed Grant of Easement, Side Letter Agreement, Order of Payment have been previously forwarded to you for your review.

This letter will also confirm that I am making you an offer in the amount of Forty Thousand, Six Hundred and Forty Six Dollars and Eighty cents (40,646.80) for a both the permanent and temporary easement rights. The offer is based on the calculations detailed below.

Permanent and Temporary Easement: \$40,646.80

We look forward to reaching an agreement with you in the very near future that will grant us the rights necessary to construct the NEXUS pipeline project. If you have any questions, please call me at 810-488-3152 or the Dundee Michigan office at 734-823-5801.

Thank you for your attention to this matter and your anticipated cooperation.

Respectfully,

Paul F. Boyce

Paul F. Boyce
Right-of-Way Project Supervisor
NEXUS Gas Transmission, LLC

GRANT OF EASEMENT

KNOW ALL PERSONS BY THESE PRESENTS: that the undersigned **The Charter Township of Ypsilanti**, A/K/A The Township of Ypsilanti, a Michigan Municipal Corporation, by Brenda L. Stumbo, Supervisor and Karen Lovejoy-Roe, Township Clerk having a mailing address of 7200 South Huron River Drive, Ypsilanti, MI 48197-7007 (hereinafter called "Grantor", whether one person or more than one), for and in consideration of the sum of Ten Dollars (\$10.00), the receipt and sufficiency of which is hereby acknowledged, paid by **NEXUS GAS TRANSMISSION, LLC**, a Delaware limited liability company, having a principal place of business at 5400 Westheimer Court, Houston, Texas 77056 (hereinafter called "Grantee" or "NEXUS"), does hereby give, grant and convey unto Grantee, its successors and assigns, subject to the limitations and reservations herein stated, an exclusive, fifty foot (50') wide permanent right-of-way and easement for the purpose of laying, constructing, maintaining, operating, altering, replacing, repairing, watering up, dewatering, changing the size of (with the same or smaller size pipeline), relocating within the Easements, abandoning and removing one (1) underground pipeline having a nominal diameter of thirty-six inches (36") or less, together with such above- or below-grade valves, fittings, meters, tie-overs, cathodic/corrosion protection, electrical interference mitigation, data acquisition and communications lines and devices, electric lines and devices, pipeline markers required by law, and other appurtenant facilities (collectively, the "Pipeline Facilities"), all of which shall be and remain the property of Grantee, for the transmission of natural gas and all by-products thereof, over, under, across, and upon the following described land (the "Easement") situated in the Township of Ypsilanti, County of Washtenaw, and State of Michigan, more fully described and referred to as:

TRACT NO(s): MI-WA-000.0001-SA-6.1-SPRD4, MI-WA-107.0020 &
MI-WA-107.0020-TAR-7-250.2

Being a portion of the land described as being in the Township of Ypsilanti, County of Washtenaw, State of Michigan, to wit: Commencing at the South 1/4 post of Section 24, Town 3 South, Range 7 East; thence North 1 degree 40'40" West 50.01 feet in the North-South 1/4 line for the point of beginning; thence South 87 degrees 16'30" West 66.01 feet; thence North 1 degree 40'40" West 830.01 feet; thence South 84 degrees 04'20" West 212.54 feet; thence North 78 degrees 43'40" West 156.92 feet; thence South 45 degrees 24'20" West 280.63

feet; thence South 69 degrees 28'20" West 311.55 feet; thence South 85 degrees 32'20" West 387.30 feet; thence North on the centerline of Bridge Road to the centerline of the Huron River; thence Easterly along the centerline of said River to the North-South 1/4 line; thence South to the point of beginning; being a part of the Southwest 1/4 of Section 24, Town 3 South, Range 7 East. (the "Property").

Parcel No. K-11-24-300-011

The Easement across the Property of Grantor is more particularly shown on the plan entitled Exhibit "A-1", Drawing No. MI-WA-107.0020, dated 03/14/2016 ("Drawing") attached hereto as Exhibit A-1 and made a part hereof.

TRACT NO(s): MI-WA-110.0000

Being a portion of the land described as being in the Township of Ypsilanti, County of Washtenaw, State of Michigan, to wit: Part of Section 24, Town 3 South, Range 7 East, described as beginning at a point located distant South 1 degree 31'13" East 1502.98 feet along the centerline of Bomber Road, coincident with the North-South 1/4 line of Section 24, Town 3 South, Range 7 East, and South 89 degrees 18'13" East 801.99 feet along the centerline of Grove Road and South 01 degree 57'13" East 674.24 feet from the North 1/4 corner of said Section 24; thence South 01 degree 57'13" East 400.23 feet to a point on the centerline of the Huron River; thence along said centerline of the Huron River, North 85 degrees 29'36" West 636.32 feet and South 76 degrees 13'06" West 272.86 feet to a point hereinafter referred to as "Point A" and South 48 degrees 00'46" West 201.80 feet and South 33 degrees 01'26" West 477.07 feet and South 23 degrees 29'55" East 125.40 feet and South 53 degrees 50'31" East 161.01 feet and South 75 degrees 57'50" East 618.47 feet and South 62 degrees 44'41" East 185.61 feet and South 15 degrees 38'32" East 129.81 feet and South 10 degrees 53'08" West 132.38 feet and South 46 degrees 23'50" West 145.00 feet and South 70 degrees 33'36" West 180.28 feet and South 87 degrees 52'44" West 405.28 feet and South 78 degrees 34'50" West 454.07 feet; thence North 01 degrees 05'30" West 541.09 feet; thence South 88 degrees 54'30" West 567.00 feet to a point on the East line of Bridge Road (66 feet wide); thence North 01 degree 05'30" West 1100.00 feet along said East line; thence North 88 degrees 56'44" East 798.38 feet to a point hereinafter referred to as "Point B"; thence North 56 degrees 18'36" East 522.80 feet; thence South 88 degrees 37'15" East 830.95 feet to the point of beginning. (the "Property").

Parcel No. K-11-24-300-001

The Easement across the Property of Grantor is more particularly shown on the plan entitled Exhibit "A-2", Drawing No. MI-WA-110.0000, dated 01/30/2016 ("Drawing") attached hereto as Exhibit A-2 and made a part hereof.

TRACT NO(s): MI-WA-112.0010

Being a portion of the land described as being in the Township of Ypsilanti, County of Washtenaw, State of Michigan, to wit: All that part of Section 23, Town 3 South, Range 7 East, Ypsilanti Township, Washtenaw County, Michigan, lying North of the Huron River and Southerly of the 686 ft. contour on the North side of the Huron River. (the "Property").

Parcel No. K-11-23-200-001

The Easement across the Property of Grantor is more particularly shown on the plan entitled Exhibit "A-3", Drawing No. MI-WA-112.0010, dated 03/03/2016 ("Drawing") attached hereto as Exhibit A-3 and made a part hereof.

TRACT NO(s): MI-WA-119.0040

Being a portion of the land described as being in the Township of Ypsilanti, County of Washtenaw, State of Michigan, to wit: Lot 1711, Watsonia Park Subdivision, according to the plat thereof as recorded in Liber 6 of Plats, Page 33, Washtenaw County Records. (the "Property").

Parcel No. K-11-13-331-014

The Easement across the Property of Grantor is more particularly shown on the plan entitled Exhibit "A-4", Drawing No. MI-WA-119.0040, dated 01/15/2016 ("Drawing") attached hereto as Exhibit A-4 and made a part hereof.

TRACT NO(s): MI-WA-119.0050

Being a portion of the land described as being in the Township of Ypsilanti, County of Washtenaw, State of Michigan, to wit: Lot 1710, Watsonia Park Subdivision, according to the plat thereof as recorded in Liber 6 of Plats, Page 33, Washtenaw County Records. (the "Property").

Parcel No. K-11-13-331-015

The Easement across the Property of Grantor is more particularly shown on the plan entitled Exhibit "A-5", Drawing No. MI-WA-119.0050, dated 01/15/2016 ("Drawing") attached hereto as Exhibit A-5 and made a part hereof.

TRACT NO(s): MI-WA-119.0060

Being a portion of the land described as being in the Township of Ypsilanti, County of Washtenaw, State of Michigan, to wit: Lots 1706, 1707, 1708, 1709, Watsonia Park Subdivision, according to the plat thereof as recorded in Liber 6 of Plats, Page 33, Washtenaw County Records. (the "Property").

Parcel No. K-11-13-331-016

The Easement across the Property of Grantor is more particularly shown on the plan entitled Exhibit "A-6", Drawing No. MI-WA-119.0060, dated 01/15/2016 ("Drawing") attached hereto as Exhibit A-6 and made a part hereof.

TRACT NO(s): MI-WA-119.0070

Being a portion of the land described as being in the Township of Ypsilanti, County of Washtenaw, State of Michigan, to wit: Lots 1704 and 1705, Watsonia Park Subdivision, according to the plat thereof as recorded in Liber 6 of Plats, Page 33, Washtenaw County Records. (the "Property").

Parcel No. K-11-13-331-017

The Easement across the Property of Grantor is more particularly shown on the plan entitled Exhibit "A-7", Drawing No. MI-WA-119.0070, dated 01/15/2016 ("Drawing") attached hereto as Exhibit A-7 and made a part hereof.

TRACT NO(s): MI-WA-122.0000

Being a portion of the land described as being in the Township of Ypsilanti, County of Washtenaw, State of Michigan, to wit: Lots 1450 through 1463, inclusive, Watsonia Park Subdivision, according to the plat thereof as recorded in Liber 6 of Plats, Page 33, Washtenaw County Records. (the "Property").

Parcel No. K-11-13-331-001

The Easement across the Property of Grantor is more particularly shown on the plan entitled Exhibit "A-8", Drawing No. MI-WA-122.0000, dated 01/15/2016 ("Drawing") attached hereto as Exhibit A-8 and made a part hereof.

TRACT NO(s): MI-WA-127.0000

Being a portion of the land described as being in the Township of Ypsilanti, Washtenaw County, State of Michigan and is described as follows: Lots 519 to 527, Watsonia Subdivision according to the plat thereof as recorded in

Liber 6 of Plats, page 33, Washtenaw County Records excepting that part of Lots 519 to 527 of said Watsonia Park Subdivision which lies Westerly of a line 61 feet Easterly of, measured at right angles, and parallel to the hereinafter described construction centerline of the relocated Northbound Detroit Industrial Expressway. The hereinbefore mentioned construction centerline of the relocated Northbound Detroit Industrial Expressway is described as follows: Commencing at the West 1/4 corner of Section 13, T3S, R7E, Michigan; thence North 86 deg. 58' 25" East, along the centerline of State Street in Watsonia Park Subdivision, 103.69 feet; thence South 1 deg. 30' 35" East, 169.27 feet to a point of beginning being the point of curve of a curve to the right, having a chord bearing North 6 deg. 35' 05" East, a radius of 2864.79 feet and a central angle of 16 deg. 11' 21"; thence Northeasterly along the arc of said curve 809.46 feet to the point of tangent; thence North 14 deg. 40' 46" East, 382.38 feet to the point of curve of a curve to the left, having a radius of 2864.79 feet and a central angle of 16 deg. 11' 21"; thence Northerly along the arc of said curve, 809.46 feet to the point of tangent; thence North 1 deg. 30' 35" West, 896.61 feet to a point of ending on the North line of said Section 13, which lies North 86 deg. 03' 35" East, 450.39 feet from the Northwest corner of said Section 13 as set forth Notice of Filing of Determination of Necessity and Taking Possession of Lands in Liber 889 page 534, Washtenaw County Records. ALSO including the Westerly 30 feet of abandoned Beverly Ave lying adjacent to Lots 519 to 527, Watsonia Park Subdivision, Liber 6 of Plats, Page 33, Washtenaw County Records; said abandonment set forth in Liber 1757, Page 947, Washtenaw County Records. (the "Property").

PART OF Parcel No. K-11-13-232-002

The Easement across the Property of Grantor is more particularly shown on the plan entitled Exhibit "A-9", Drawing No. MI-WA-127.0000, dated 03/16/2016 ("Drawing") attached hereto as Exhibit A-9 and made a part hereof.

1. Notwithstanding anything to the contrary as shown on the Drawing, the permanent and exclusive easement rights granted to Grantee shall extend to and include contiguous public or private roads and ways to the full extent of Grantor's interest therein for the purpose of ingress and egress to the Easement.

2. Also included in this Grant of Easement is the use of the following if and to the extent shown on the Drawing: (a) temporary access roads (the "Temporary Access Road", whether one or more) to access the Temporary Work Space (as herein defined) and the Easement; (b) temporary work space (the "Temporary Work Space") adjacent to and generally

parallel with the Easement for construction, operation and maintenance of the Pipeline Facilities. Grantor's granting of the Temporary Access Road and Temporary Work Space to Grantee shall be on an exclusive basis during the full term of twenty four (24) months from the start of construction of the Pipeline Facilities on the Property. Grantor shall grant no third party any right to use the Temporary Access Road or Temporary Work Space prior to the expiration of Grantee's exclusive term to use the Temporary Access Road and/or Temporary Work Space.

3. Grantee intends to use the area described on Exhibit "A" attached hereto as "Exhibit A" for the purposes of storing, bending, welding and testing of pipe and for valve and other appurtenant facility assembly operations, and for storing of other pipeline-related materials including, but not limited to, construction equipment (the "Staging Area"). The Staging Area may also be used for the following purposes: parking of vehicles including trucks, vans and construction equipment, the rights of ingress and egress to and from the Staging Area for enjoyment of Grantee's parking rights, the temporary storage of soils during the construction of Grantee's pipeline project, fabrication, material storage, painting of equipment and related pipeline construction activities. Vehicles may be owned or operated by individual agents or employees of the Grantee or its contractors or private parties. Grantee and its contractors may also set up, operate and maintain portable office trailers with associated electric power and telephone services on the Staging Area during the term of these twenty-four (24) months from the start of construction to facilitate Grantee's pipeline construction and restoration operations.

4. Grantee shall have all other rights and benefits necessary or convenient for the full enjoyment and use of the rights herein granted, including, but not limited to, the right, to be exercised at any time in Grantee's sole and absolute discretion, to remove, clear and to keep clear all buildings (including, but not limited to, sheds, garages, and other structures, whether on foundations or not), walls or similar structures, above- or below-ground swimming pools, decks, rocks, trees, brush, limbs, and other obstructions including, but not limited to, pipelines and conduits within the Easement, Temporary Access Road and Temporary Work Space (prior to the expiration of Grantee's right to use the Temporary Access Road and Temporary Work Space as to the Temporary Work Space and Temporary Access Road only) that may interfere with the Grantee's use of the Easement, Temporary Access Road and Temporary Work Space (prior to the expiration of Grantee's right to use the Temporary Work Space and Temporary Access Road as to the Temporary Work Space and Temporary Access Road only), and the free and full right of ingress and egress, over and across said Easement, Temporary Access Road and Temporary Work Space (prior to the expiration of Grantee's right to use the Temporary Work Space and Temporary Access Road as to the Temporary Work Space and Temporary Access Road only). Subject to the terms of this Grant of Easement, after construction and installation of the Pipeline Facilities is completed, Grantor may plant crops (but in no event trees) within the Easement and harvest the same from time-to-time.

5. Grantor and Grantee agree that the consideration for this Grant of Easement includes payment for the value of the rights granted to Grantee by Grantor, and all damages of every kind and character and clean-up costs for initial construction and installation of the Pipeline Facilities including damages to growing crops and timber, and the reestablishment of growing crops. Grantee shall pay Grantor the fair market value for any and all damages to growing crops, cultivated land, pasturage, timber, fences, drain tile, or buildings of Grantor resulting from the exercise of the rights herein granted subsequent to the initial construction of the Pipeline Facilities; provided, however, that after the Pipeline Facilities have been constructed hereunder, Grantee shall not be liable for damages in the future caused by keeping the Easement clear of trees, undergrowth, brush, structures, or any other obstructions. In the event the Property or any part of the Property is subject to an existing surface lease, any and all damages sustained by the existing surface tenant to crops, timber or other property belonging to the surface lease tenant as a result of the Grantee's use of this Grant of Easement, shall, following payment from Grantee to Grantor hereunder, be promptly remitted to the surface tenant by Grantor.

6. The pipeline shall be buried to at least the minimum depth required by applicable laws and regulations.

7. Grantor shall not grade, excavate, fill or flood the Easement, Temporary Access Road and/or Temporary Work Space (prior to the expiration of Grantee's right to use the Temporary Work Space and Temporary Access Road, as to the Temporary Work Space and Temporary Access Road only) without obtaining the Grantee's prior written consent, which may be withheld in Grantee's sole discretion.

8. Grantor shall retain any interest which Grantor has in and to the oil, gas, and other minerals in, on and under the Easement; provided, however, that if Grantor owns such minerals, Grantor shall not be permitted to drill or operate equipment for the production or development of minerals on the Easement, but it will be permitted to extract the oil and other minerals from and under the Easement by directional drilling and other means, so long as such activities do not damage, destroy, injure, and/or interfere with Grantee's use of the Easement for the purposes for which the Easement has been acquired by Grantee.

9. The rights, title and privileges herein granted may, in whole or in part, be sold, leased, assigned, pledged and mortgaged, and shall inure to the benefit of the Grantee and its successors, assigns, heirs and legal representatives. The burdens of this Grant of Easement shall run with and against the Property and shall be a charge and burden on the Property and shall be binding upon and against Grantor and its successors, assigns, permittees, licensees, lessees, employees and agents.

10. The failure of Grantee to exercise or any delay of Grantee in exercising any rights herein conveyed in any single instance or from time to time shall not be considered or construed

as a waiver of such right or rights and shall not bar Grantee from exercising such right or rights, or, if necessary, seeking an appropriate remedy in conjunction with the exercise or violation of such right or rights from time to time.

11. Grantor understands and agrees that the person securing this grant is without authority from Grantee to make any agreement in respect of the subject matter hereof not herein expressed.

12. This Grant of Easement shall terminate, or be deemed to have terminated, if and only if (i) the Federal Energy Regulatory Commission, or its successor agency, has issued an authorization for Grantee to abandon the Pipeline Facilities or (ii) Grantee notifies Grantor in writing of its intent to terminate this Grant of Easement. In the event of any such termination and upon the written request of Grantor, Grantee shall furnish Grantor with a release of the Grant of Easement.

13. Any and all written notices to which the parties shall be entitled hereunder or under any law, statute, rule, regulation, order, ordinance or policy of any governmental agency or entity having jurisdiction of the subject matter for which this Grant of Easement is granted, shall be deemed delivered when the same has been placed in the U.S. Mail in a properly stamped envelope or other appropriate mail container, addressed to the addresses shown below, bearing the adequate amount of postage to result in delivery of same to the address shown thereon, and sent by certified mail, return receipt requested, to the party to whom such notice is given. In the alternative, either party may give such notice by United Parcel Service (UPS), Federal Express or other similar national expedited mail service guaranteeing not later than two (2) day delivery of any such letter or notice to the addresses provided for herein.

- a) Grantor and Grantee designate the following persons, addresses for all notices and information to be delivered hereunder:

Grantor: The Charter Township of Ypsilanti,
Attention: Brenda L. Stumbo, Supervisor &
Karen Lovejoy-Roe, Township Clerk
7200 South Huron River Drive, Ypsilanti, MI 48197-7007

Grantee: NEXUS Gas Transmission, LLC,
5400 Westheimer Court, Houston, Texas 77056

- b) Such persons, addresses may be changed by the respective party by delivering written notice of such change to the other party.

14. This Grant of Easement shall be interpreted, enforced and governed under the laws of the State of Michigan. Venue for any dispute arising under this Grant of Easement shall be proper in either a state court in the county where the Property is located, or the Michigan federal court having jurisdiction over the county in which the Property is located.

15. The undersigned, states, affirms and certifies as of the date hereof that the undersigned is the legal owner of the Property and is authorized pursuant to the laws of the State of Michigan to execute, acknowledge and deliver this Grant of Easement in the Property of Grantor. If Grantor is married and holds title to the Property in his or her name only, his or her spouse is signing this Grant of Easement to release dower in the property rights granted and conveyed herein.

16. The execution, delivery, and performance of this Grant of Easement have been duly and validly authorized by all requisite action, corporate or otherwise, on the part of the Grantor and Grantee.

17. From time to time, and at the request of Grantee, the Grantor (without additional consideration) shall execute and deliver such additional documents and instruments which are necessary or appropriate to effectuate and perform the provisions of this Grant of Easement.

18. Grantee agrees to indemnify and hold harmless Grantor from and against claims, actions, suits, or demands for injuries and damages occurring as a direct result of Grantee's negligence or intentional misconduct in using the Easement Area, except to the extent such damages, costs, claims or liabilities arise from Grantor's negligence or intentional misconduct, or any actions or omissions of Grantor, their employees, agents, invitees, or lessees for which such parties may be strictly liable under law.

19. This instrument is exempt from transfer taxes pursuant to MCL 207.505(a), MCL 207.505(f), MCL 207.526(a), MCL 207.526(f), and MCL 211.8(g).

[Signatures begin on following page]

IN WITNESS WHEREOF, Grantor executes this Grant of Easement this _____ day of _____, 2016.

Grantor:

**The Charter Township of Ypsilanti,
A/K/A The Township of Ypsilanti,
a Michigan Municipal Corporation**

X _____
Brenda L. Stumbo, Supervisor

X _____
Karen Lovejoy-Roe, Township Clerk

ACKNOWLEDGMENT

STATE OF _____ }
 } SS
COUNTY OF _____ }

On this ____ day of _____, 2016, before me, the undersigned notary public, personally appeared Brenda L. Stumbo, who proved to me through satisfactory evidence of identification, which was _____, acknowledged herself to be Supervisor of The Charter Township of Ypsilanti, A/K/A The Township of Ypsilanti, a Michigan Municipal Corporation, being authorized to do so, executed the foregoing instrument as the act and deed of such corporation for the purposes therein contained by signing the name of such corporation/company, and acknowledged to me that she signed it voluntarily, for its stated purposes.

My Commission Expires: _____
_____, Notary Public
_____, County, Michigan
Acting in _____ County, Michigan

ACKNOWLEDGMENT

STATE OF _____ }
 } SS
COUNTY OF _____ }

On this ____ day of _____, 2016, before me, the undersigned notary public, personally appeared Karen Lovejoy-Roe, who proved to me through satisfactory evidence of identification, which was _____, acknowledged herself to be Township Clerk of The Charter Township of Ypsilanti, A/K/A The Township of Ypsilanti, a Michigan Municipal Corporation, being authorized to do so, executed the foregoing instrument as the act and deed of such corporation for the purposes therein contained by signing the name of such corporation/company, and acknowledged to me that she signed it voluntarily, for its stated purposes.

My Commission Expires: _____
_____, Notary Public

Acting in _____ County, Michigan

RECORD AND RETURN TO:
NEXUS Gas Transmission, LLC
Attention: Right-of-Way Department
98 Main Street
Dundee, MI 48131-1202

Tract No: MI-WA-000.0001-SPRD4,
MI- WA-107.0020,
MI-WA-107.0020-TAR-7-250.2
MI-WA-110.0000, MI-WA-112.0010,
MI-WA-119.0040, MI-WA-119.0050,
MI-WA-119.0060, MI-WA-119.0070,
MI-WA-122.0000 & MI-WA-127.0000
State: Michigan

This instrument prepared by: Jeff Dehner, Esq., 6050 Oak Tree Blvd, Suite 200, Independence, Ohio 44131

Date: _____, 2016

The Charter Township of Ypsilanti
7200 South Huron River Drive
Ypsilanti, MI 48197-7007

ATTENTION: Brenda L. Stumbo, Supervisor and
Karen Lovejoy-Roe, Township Clerk

Re: NEXUS Gas Transmission, LLC ("NEXUS") Project Letter Agreement
MI-WA-000.0001-SA-6.1-SPRD4, MI-WA-107.0020, MI-WA-107.0020-TAR-7-250.2,
MI-WA-110.0000, MI-WA-112.0010, MI-WA-119.0040, MI-WA-119.0050, MI-WA-119.0060,
MI-WA-119.0070, MI-WA-122.0000 & MI-WA-127.0000, Washtenaw County, Michigan
Tax Parcel ID Number: K-11-24-300-011, K-11-24-300-001, K-11-23-200-001, K-11-13-331-014,
K-11-13-331-015, K-11-13-331-016, K-11-13-331-017, K-11-13-331-001 &
PART OF K-11-13-232-002
Grant of Easement ("Underlying Agreement")

Dear Ms. Stumbo and Ms. Lovejoy-Roe,

You have stated your willingness to enter into the above-referenced Underlying Agreement with NEXUS Gas Transmission, LLC ("NEXUS") regarding its plans to install a natural gas transmission pipeline, utilize a staging area and temporary access road on or near your property located in Washtenaw County, Michigan ("Property") as part of NEXUS' new interstate natural gas pipeline system (the "NEXUS Project"). However, as inducement for you to enter into the Underlying Agreement, you have requested, and the parties agree, that the following additional terms and conditions shall apply to NEXUS' use of the Property for the NEXUS Project:

1. At those times NEXUS is performing work within the Easement and/or Temporary Workspace, NEXUS will ensure that the Easement and Temporary Workspace are clean of its construction debris and litter, which will not be buried within the Easement or Temporary Workspace.
2. NEXUS agrees to restore the Property to as near as reasonably possible to what existed prior to the start of construction of the Pipeline Facilities on the Property.
3. If the Easement and/or Temporary Workspace is located in a cultivated field or lawn, NEXUS will remove rocks unearthed during construction activities within the disturbed areas of the Easement and/or Temporary Workspace.
4. Topsoil segregation will be conducted in lawns. At completion subsoil will be chisel plowed in travel lane, rocks will be picked up and topsoil replaced. Grantee shall hire a local licensed landscaper to restore lawn and utilize seed type as requested by landowner.
5. This Letter Agreement shall remain applicable only for twenty-four (24) months from the start of construction.
6. This Letter Agreement, the Underlying Agreement, and any exhibits thereto constitute the entire agreement between the parties and there are no other agreements, promises, representations or understandings as to the matters addressed herein except as expressly set forth herein.

7. This Letter Agreement is binding on the heirs, executors, administrators, successors and assigns of NEXUS but is personal to the undersigned.
8. This Letter Agreement shall not be recorded, distributed, disclosed, or utilized by you or any person acting on your behalf, and you and all such persons shall keep confidential this Letter Agreement and all the terms and shall not disclose to any person or entity the existence of this Letter Agreement unless and insofar as: (a) ordered to do so by a court of competent jurisdiction; or (b) it is necessary for an attorney or accountant to render professional advice or services to or for the benefit of the undersigned (the restrictions stated in this paragraph shall automatically apply to the attorney and/or accountant, and the undersigned shall so advise such person(s)).
9. Any attempt by the undersigned or their heirs, successors, assigns, representatives or attorneys or agents to record in the public record (e.g., a county recorder's office) this Letter Agreement or a copy of it as a stand-alone instrument or as an exhibit attachment or schedule to an affidavit or other recordable instrument or document shall render this Letter Agreement null, void, and unenforceable.

If the foregoing is acceptable to you, please indicate your agreement thereto by signing two (2) originals of this letter in the space provided below, retaining one (1) original for your records, and returning one (1) original to the undersigned.

If you have any questions or concerns that I did not address in this letter, please do not hesitate to contact us at the Project Hotline toll-free at 1-844-589-3655.

Sincerely,

Walton Johnson
ROW Project Manager
NEXUS Gas Transmission, LLC

Accepted:

**The Charter Township of Ypsilanti,
a Michigan Municipal Corporation**

Brenda L. Stumbo, Supervisor

Date

Karen Lovejoy-Roe, Township Clerk

Date

Tract Number(s): MI-WA-000.0001-SA-6.1-SPRD4, MI-WA-107.0020,
MI-WA-107.0020-TAR-7-250.2, MI-WA-110.0000, MI-WA-112.0010,
MI-WA-119.0040, MI-WA-119.0050, MI-WA-119.0060,
MI-WA-119.0070, MI-WA-122.0000 & MI-WA-127.0000

Landowner(s): The Charter Township of Ypsilantia, A/K/A The Township of Ypsilanti

Tax Parcel ID Number(s): K-11-24-300-011, K-11-24-300-001, K-11-23-200-001, K-11-13-331-014,
K-11-13-331-015, K-11-13-331-016, K-11-13-331-017, K-11-13-331-001
and A PART OF K-11-13-232-002

NEXUS GAS TRANSMISSION, LLC ORDER OF PAYMENT

Date: _____

Contemporaneous to the execution of this Order of Payment, Grantor/Payee executed a Grant of Easement covering the lands described above. Grantee/Payor shall tender the payment below to Grantor/Payee as indicated herein by check. Grantor/Payee acknowledges and agrees that he/she has read and understands the terms and provisions of the Grant of Easement and this Order of Payment. Non-acceptance by Grantor/Payee of timely payment shall not serve to void the Grant of Easement.

Payment for the rights granted to NEXUS Gas Transmission, LLC are in the total amount of \$ **40,646.80**. This payment consists of the following:

Easement (100.00% of total payment) - \$ 40,646.80;

And

Damages (0.00% of total payment) - \$ 0.00.

**The Charter Township of Ypsilanti,
A/K/A The Township of Ypsilanti,
a Michigan Municipal Corporation**

Grantor/Payee's signature: _____
Brenda L. Stumbo, Supervisor

Date: _____

Grantor/Payee's signature: _____
Karen Lovejoy-Roe, Township Clerk

Date: _____

	DATE PAID	PAID BY
	AMOUNT	CHECK NUMBER

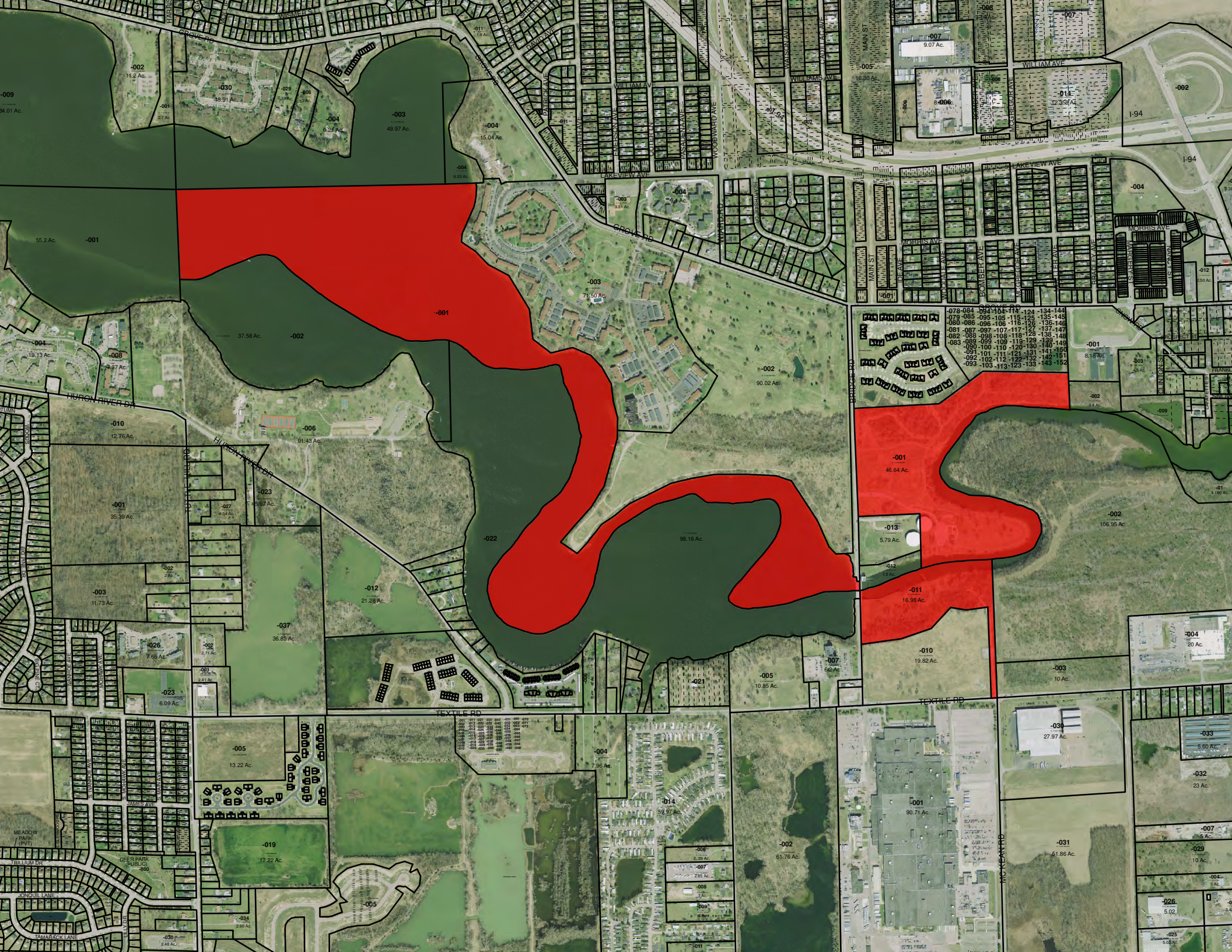

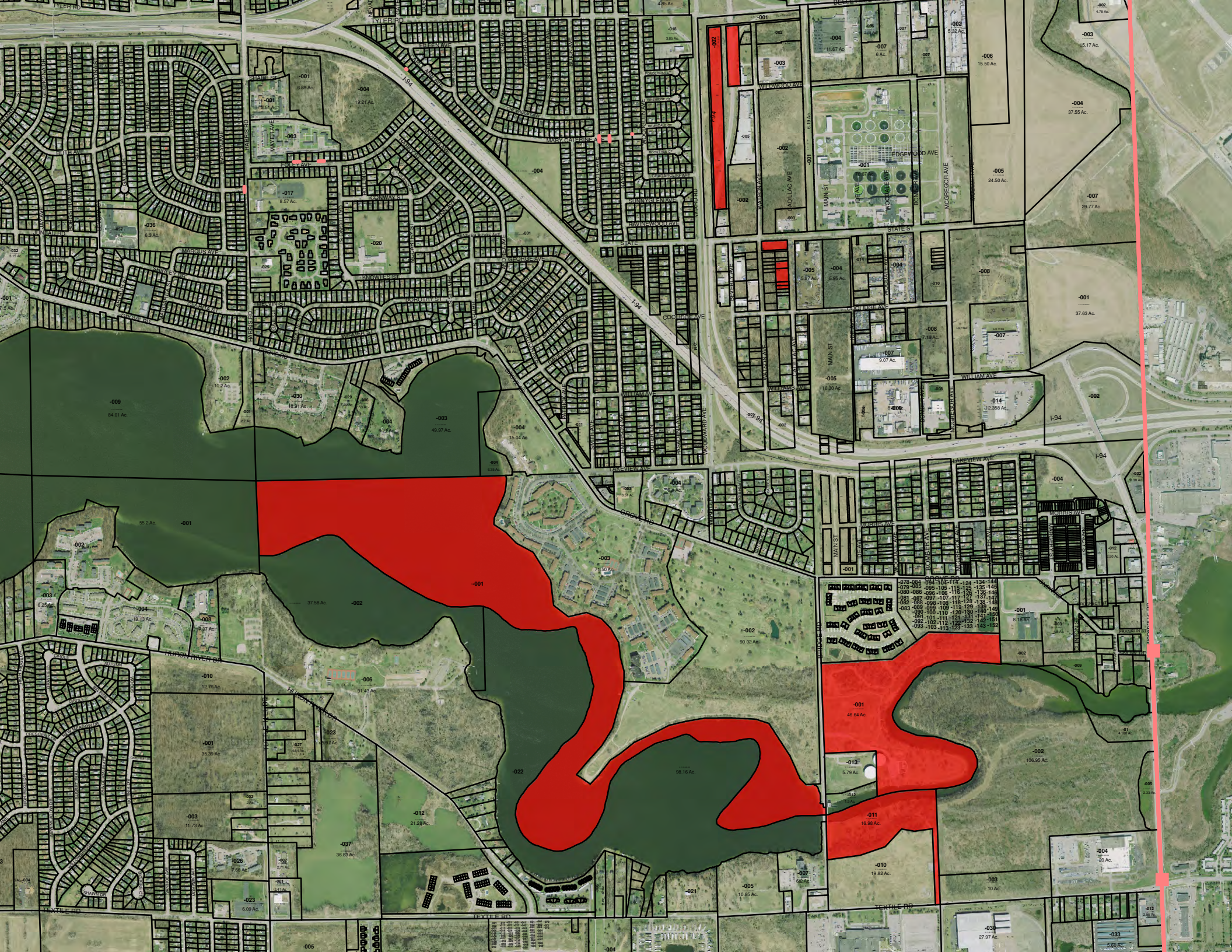

-037
4.85 Ac.

-018
3.85 Ac.

-017
1.65 Ac.

-001

-002

-003

-002

-002

-003

BELLEVILLE TYLER RD

-006
2.19 Ac.

-007
3.79 Ac.

-007
6 Ac.

-009
1.35 Ac.

-002
5.32 Ac.

-006
15.50 Ac.

-002
1-94

6.19 Ac.

-001
70.67 Ac.

DESOTO AVE
NASH AVE
WOODGLEN AVE
PONDEROSA CT
PINERIDGE CT
BRIARDALE CT
BOOKTREE CT
CEDARCLIFF AVE
SUNNYGLEN AVE
RAVINEWOOD AVE
WARD RD

WILDWOOD AVE

WATSON AVE

CADILLAC AVE

MAIN ST

IDE AVE

WOODALE AVE

BOMBER AVE

MCGREGOR AVE

MOELLER AVE

EDGEWOOD AVE

STATE ST

STATE

1-94

BEVERLY AVE

WOODALE AVE

COOLIDGE AVE

ALLEY

AVE

-008
-009
-016

-001
-002
-003
-010
-017
-016
-007
-008
-008
-004
-005
-007
-008
-009
-010
-011

-005
5.87 Ac.
-004
5.95 Ac.
-014
-003
-004
-005
-008
-012
-010

-008
-010

EXHIBIT "A"-1

YPSILANTI TOWNSHIP, WASHTENAW COUNTY, MICHIGAN
T 3 S, R 7 E : SECTION 24
MICHIGAN SURVEY

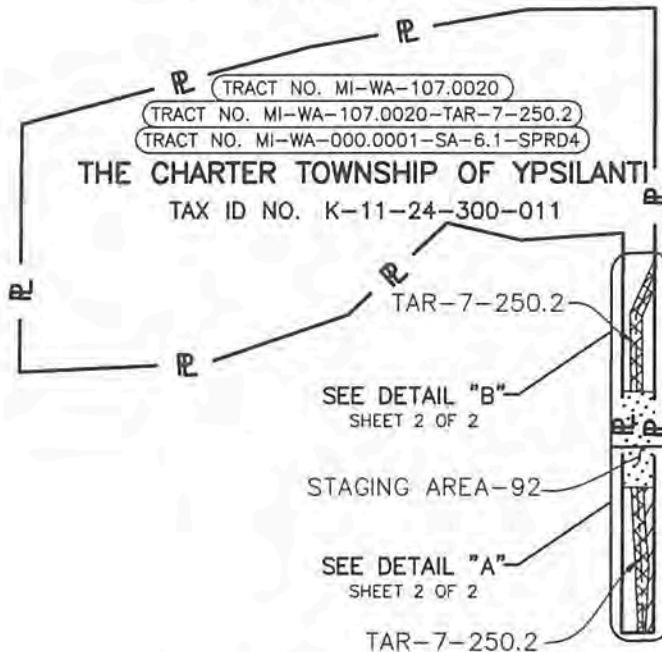
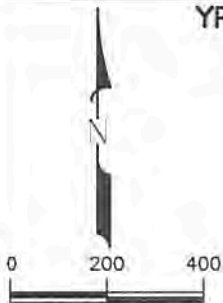

	PROP. TEMP. WORKSPACE (T.W.S.):	0.1 ± ACRE
	TEMP. ACCESS ROAD (TAR):	555' ±
	AREA OF TEMP. ACCESS ROAD (TAR):	0.3 ± ACRE
	STAGING AREA T.W.S.:	0.3 ± ACRE

REVISIONS 0 ISSUED FOR ACQUISITION - 03/18/2016

SURVEYOR'S SEAL



NOTES:

1. THE ACTUAL LOCATION OF THE NEW PERMANENT EASEMENT IS DETERMINED BY THE FIRST PIPELINE AS INSTALLED.
2. ALL BEARINGS AND DISTANCES (US SURVEY FEET) HEREIN ARE GRID AND BASED UPON THE UNIVERSAL TRANSVERSE MERCATOR PROJECTION, ZONE 17 NORTH (UTM17N), NORTH AMERICAN DATUM OF 1983 (NAD83 (2011)).
3. I HEREBY CERTIFY THAT THIS EASEMENT EXHIBIT IS NOT A BOUNDARY SURVEY OR CERTIFIED SURVEY AND WAS PREPARED UNDER MY DIRECT SUPERVISION FROM RECORD DATA ONLY. THE INFORMATION WITHIN THIS EXHIBIT IS NOT INTENDED TO MEET THE REQUIREMENTS OF A CERTIFIED SURVEY AS DEFINED BY PUBLIC ACT 132 OF 1970, AS AMENDED, OR ANY OTHER APPLICABLE SURVEYING LAW WITHIN THE STATE OF MICHIGAN.

D.A. Parsell

03.18.2016

DANA A. PARSELL, P.S.
MICHIGAN PROFESSIONAL SURVEYOR #51483

DATE:

PREPARED FOR:

NEXUS Gas
Transmission, LLC



PREPARED BY:



4848 LOOP CENTRAL DR.
Suite 100
HOUSTON, TX. 77081
PH. 713-977-7770

JOB NO.

22203

DATE:

03/14/2016

DRAWN:

LBJ

APPROVED:

DP

SCALE:

1"=400'

SHEET

1 OF 2

EXHIBIT "A"-1

THE PROPERTY OF
THE CHARTER
TOWNSHIP OF YPSILANTI

DOC. NO.

22203-250-PSK-40260

DWG. NO.

MI-WA-107.0020

REV

0

EXHIBIT "A"-1

YPSILANTI TOWNSHIP, WASHTENAW COUNTY, MICHIGAN

T 3 S, R 7 E : SECTION 24

MICHIGAN SURVEY

CONTINUED TO DETAIL "B"
SHEET 2 OF 2

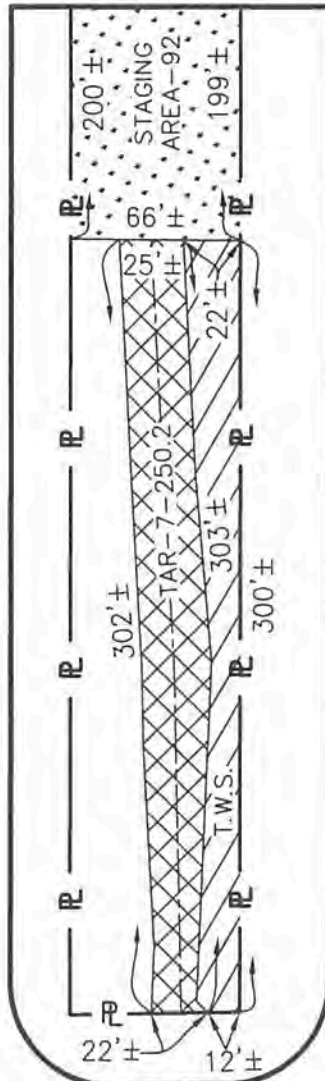

DETAIL "A"
N.T.S.

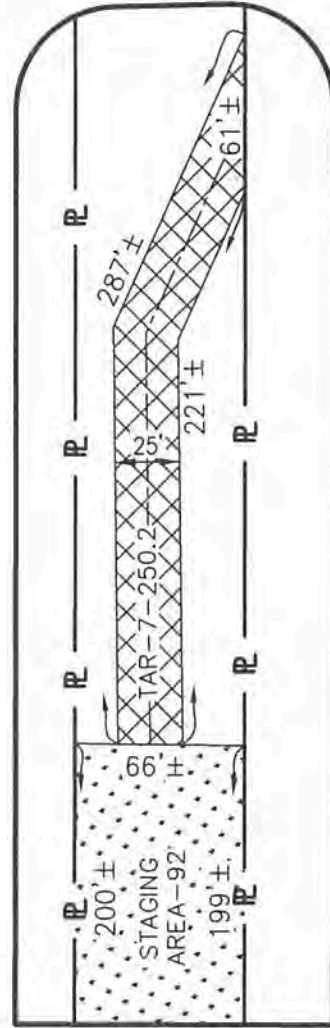

CONTINUED FROM DETAIL "A"
SHEET 2 OF 2

DETAIL "B"
N.T.S.

REVISIONS 0 ISSUED FOR ACQUISITION - 03/18/2016

PREPARED FOR:

NEXUS Gas Transmission, LLC



PREPARED BY:



4848 LOOP CENTRAL DR.
Suite 100
HOUSTON, TX. 77081
PH. 713-977-7770

JOB NO.

22203

DATE:

03/14/2016

DRAWN:

LBJ

APPROVED:

DP

SCALE:

N.T.S.

SHEET 2 OF 2

EXHIBIT "A"-1
THE PROPERTY OF
THE CHARTER
TOWNSHIP OF YPSILANTI

DOC. NO.
22203-250-PSK-40260

DWG. NO.
MI-WA-107.0020

REV 0

EXHIBIT "A"-2

YPSILANTI TOWNSHIP, WASHTENAW COUNTY, MICHIGAN
 T 3 S, R 7 E : SECTION 24
 MICHIGAN SURVEY

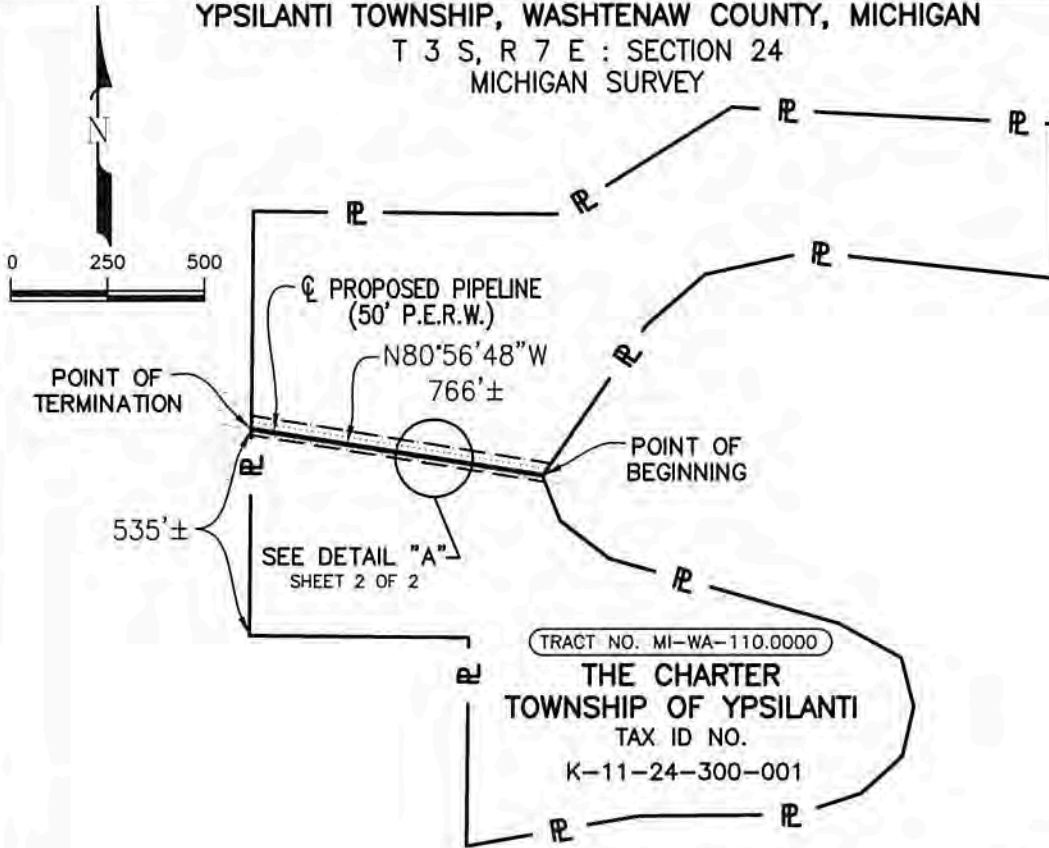

— PROP. PIPELINE: 766' ±
 [---] PROP. PERM. EASEMENT (P.E.R.W.): 0.9 ± ACRE

REVISIONS 0 ISSUED FOR ACQUISITION - 02/04/2016

SURVEYOR'S SEAL



NOTES:

1. THE ACTUAL LOCATION OF THE NEW PERMANENT EASEMENT IS DETERMINED BY THE FIRST PIPELINE AS INSTALLED.
2. ALL BEARINGS AND DISTANCES (US SURVEY FEET) HEREIN ARE GRID AND BASED UPON THE UNIVERSAL TRANSVERSE MERCATOR PROJECTION, ZONE 17 NORTH (UTM17N), NORTH AMERICAN DATUM OF 1983 (NAD83 (2011)).
3. I HEREBY CERTIFY THAT THIS EASEMENT EXHIBIT IS NOT A BOUNDARY SURVEY OR CERTIFIED SURVEY AND WAS PREPARED UNDER MY DIRECT SUPERVISION FROM RECORD DATA ONLY. THE INFORMATION WITHIN THIS EXHIBIT IS NOT INTENDED TO MEET THE REQUIREMENTS OF A CERTIFIED SURVEY AS DEFINED BY PUBLIC ACT 132 OF 1970, AS AMENDED, OR ANY OTHER APPLICABLE SURVEYING LAW WITHIN THE STATE OF MICHIGAN.

D.A.P.

02.05.2016

DANA A. PARSELL, P.S.
 MICHIGAN PROFESSIONAL SURVEYOR #51483

DATE:

PREPARED FOR:

NEXUS Gas Transmission, LLC



PREPARED BY:



4848 LOOP CENTRAL DR.
 Suite 100
 HOUSTON, TX. 77081
 PH. 713-977-7770

JOB NO.

22203

DATE:

01/30/2016

DRAWN:

LBJ

APPROVED:

DP

SCALE:

1"=500'

SHEET

1 OF 2

DOC. NO.

22203-250-PSK-40235

DWG. NO.

MI-WA-110.0000

REV

0

EXHIBIT "A"-2

THE PROPERTY OF
 THE CHARTER
 TOWNSHIP OF YPSILANTI

EXHIBIT "A"-2

YPSILANTI TOWNSHIP, WASHTENAW COUNTY, MICHIGAN
 T 3 S, R 7 E : SECTION 24
 MICHIGAN SURVEY

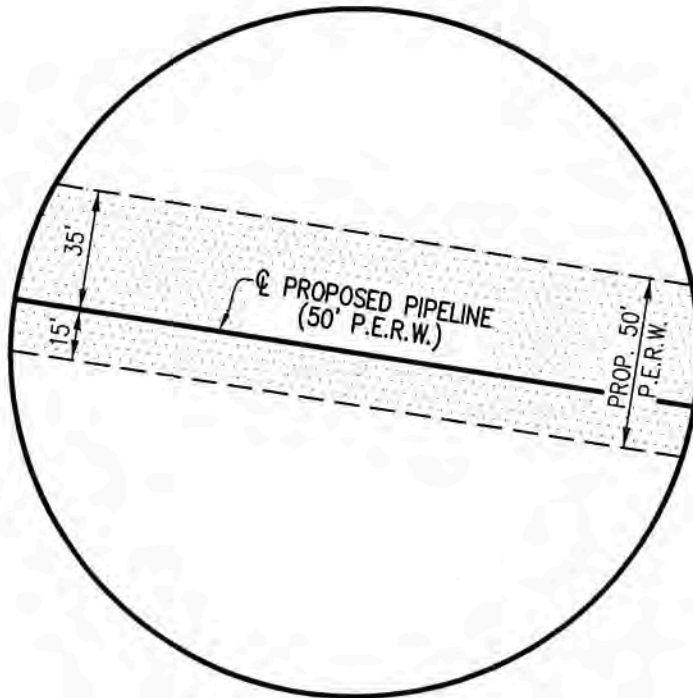

DETAIL "A"
 N.T.S.

REVISIONS 0 ISSUED FOR ACQUISITION - 02/04/2016

PREPARED FOR:

NEXUS Gas
 Transmission, LLC



PREPARED BY:



Universal Pegasus
 INTERNATIONAL
A Subsidiary of Huntington Ingalls Industries
 COA: Universal Enasco, Inc.

4848 LOOP CENTRAL DR.
 Suite 100
 HOUSTON, TX. 77081
 PH. 713-977-7770

JOB NO.

22203

DATE:

01/30/2016

DRAWN:

LBJ

APPROVED:

DP

SCALE:

N.T.S.

SHEET
 2 OF 2

DOC. NO.
 22203-250-PSK-40235

DWG. NO.
 MI-WA-110.0000

REV
 0

EXHIBIT "A"-2

THE PROPERTY OF
 THE CHARTER
 TOWNSHIP OF YPSILANTI

EXHIBIT "A"-3

YPSILANTI TOWNSHIP, WASHTENAW COUNTY, MICHIGAN
 T 3 S, R 7 E : SECTIONS 23 & 24
 MICHIGAN SURVEY

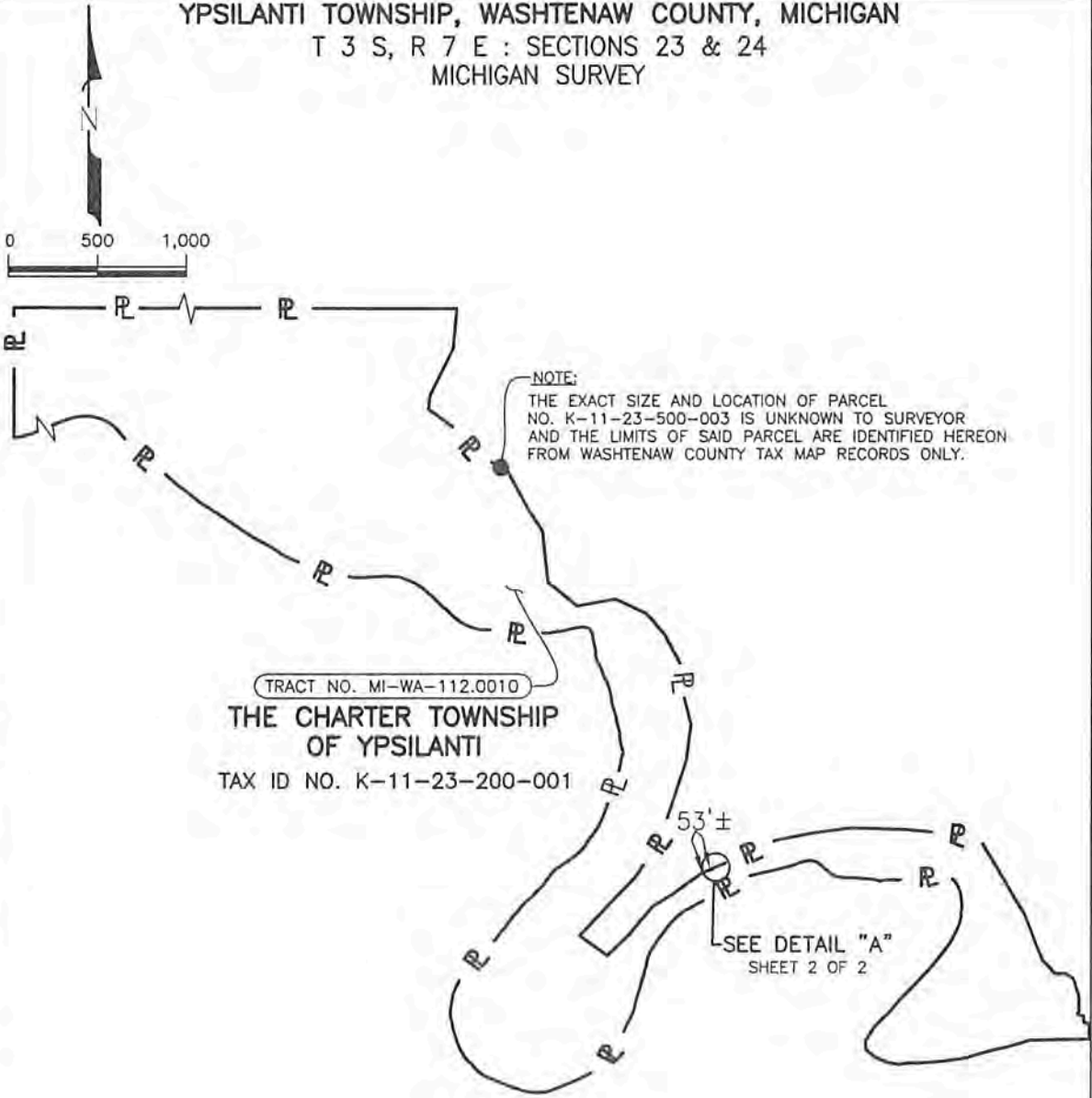

NOTE:
 THE EXACT SIZE AND LOCATION OF PARCEL
 NO. K-11-23-500-003 IS UNKNOWN TO SURVEYOR
 AND THE LIMITS OF SAID PARCEL ARE IDENTIFIED HEREON
 FROM WASHTENAW COUNTY TAX MAP RECORDS ONLY.

TRACT NO. MI-WA-112.0010

THE CHARTER TOWNSHIP
 OF YPSILANTI

TAX ID NO. K-11-23-200-001

SEE DETAIL "A"
 SHEET 2 OF 2

AREA OF HTAR-2: 188 ± SQ. FT.

REVISIONS 0 ISSUED FOR ACQUISITION - 03/14/2016

PREPARED FOR: NEXUS Gas Transmission, LLC 	PREPARED BY: Universal Pegasus INTERNATIONAL <small>A Subsidiary of Huntington Ingalls & Associates COA: Universal Enaco, Inc.</small> 4848 LOOP CENTRAL DR. Suite 100 HOUSTON, TX. 77081 PH. 713-977-7770	JOB NO. 22203	EXHIBIT "A"-3 THE PROPERTY OF THE CHARTER TOWNSHIP OF YPSILANTI		
		DATE: 03/03/2016 DRAWN: LBJ APPROVED: DP			
SCALE: 1"=1,000'		SHEET 1 OF 2	DOC. NO. 22203-250-PSK-40252	DWG. NO. MI-WA-112.0010	REV 0

EXHIBIT "A" - 3

YPSILANTI TOWNSHIP, WASHTENAW COUNTY, MICHIGAN

T 3 S, R 7 E : SECTIONS 23 & 24
MICHIGAN SURVEY

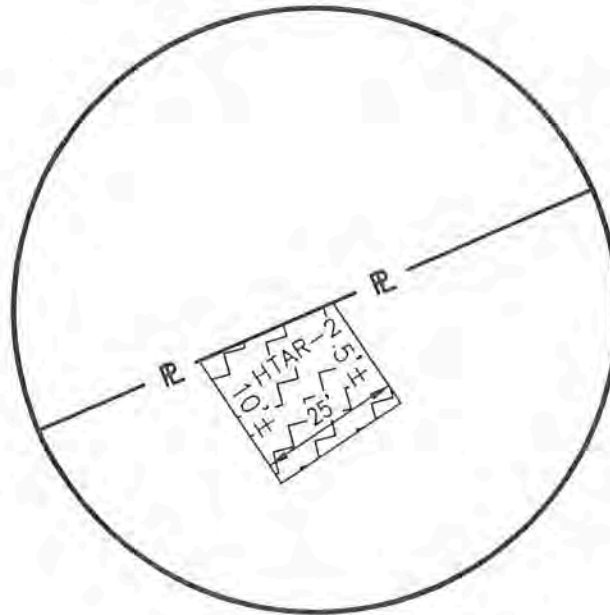

DETAIL "A"

N.T.S.

REVISIONS 0 ISSUED FOR ACQUISITION - 03/14/2016

SURVEYOR'S SEAL



NOTES:

1. THE ACTUAL LOCATION OF THE NEW PERMANENT EASEMENT IS DETERMINED BY THE FIRST PIPELINE AS INSTALLED.
2. ALL BEARINGS AND DISTANCES (US SURVEY FEET) HEREIN ARE GRID AND BASED UPON THE UNIVERSAL TRANSVERSE MERCATOR PROJECTION, ZONE 17 NORTH (UTM17N), NORTH AMERICAN DATUM OF 1983 (NAD83 (2011)).
3. I HEREBY CERTIFY THAT THIS EASEMENT EXHIBIT IS NOT A BOUNDARY SURVEY OR CERTIFIED SURVEY AND WAS PREPARED UNDER MY DIRECT SUPERVISION FROM RECORD DATA ONLY. THE INFORMATION WITHIN THIS EXHIBIT IS NOT INTENDED TO MEET THE REQUIREMENTS OF A CERTIFIED SURVEY AS DEFINED BY PUBLIC ACT 132 OF 1970, AS AMENDED, OR ANY OTHER APPLICABLE SURVEYING LAW WITHIN THE STATE OF MICHIGAN.

D. Parsell

03.18.2016

DANA A. PARSELL, P.S.
MICHIGAN PROFESSIONAL SURVEYOR #51483

DATE:

PREPARED FOR:

NEXUS Gas
Transmission, LLC



PREPARED BY:



4848 LOOP CENTRAL DR.
Suite 100
HOUSTON, TX. 77081
PH. 713-977-7770

JOB NO.

22203

DATE:

03/03/2016

DRAWN:

LBJ

APPROVED:

DP

SCALE:

N.T.S.

SHEET
2 OF 2

DOC. NO.
22203-250-PSK-40252

DWG. NO.
MI-WA-112.0010

REV
0

EXHIBIT "A" - 3

THE PROPERTY OF
THE CHARTER TOWNSHIP
OF YPSILANTI

EXHIBIT "A"-4

YPSILANTI TOWNSHIP, WASHTENAW COUNTY, MICHIGAN
 T 3 S, R 7 E : SECTION 13
 MICHIGAN SURVEY

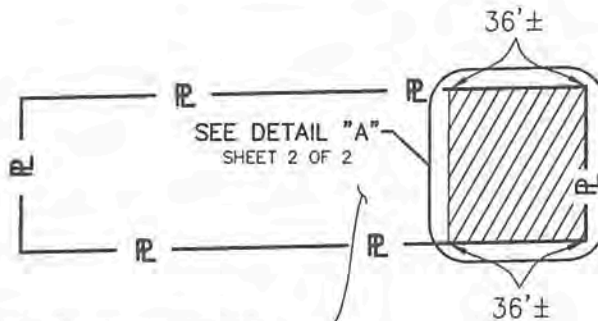
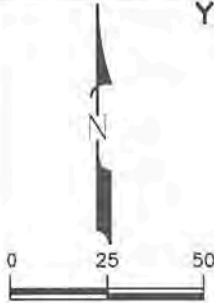

TRACT NO. MI-WA-119.0040

CHARTER TOWNSHIP OF YPSILANTI
 TAX ID NO. K-11-13-331-014

REVISIONS 0 ISSUED FOR ACQUISITION - 01/28/2016

SURVEYOR'S SEAL



PROP. TEMP. WORKSPACE (T.W.S.): 1,425 ± SQ. FT.

NOTES:

1. THE ACTUAL LOCATION OF THE NEW PERMANENT EASEMENT IS DETERMINED BY THE FIRST PIPELINE AS INSTALLED.
2. ALL BEARINGS AND DISTANCES (US SURVEY FEET) HEREIN ARE GRID AND BASED UPON THE UNIVERSAL TRANSVERSE MERCATOR PROJECTION, ZONE 17 NORTH (UTM17N), NORTH AMERICAN DATUM OF 1983 (NAD83 (2011)).
3. I HEREBY CERTIFY THAT THIS EASEMENT EXHIBIT IS NOT A BOUNDARY SURVEY OR CERTIFIED SURVEY AND WAS PREPARED UNDER MY DIRECT SUPERVISION FROM RECORD DATA ONLY. THE INFORMATION WITHIN THIS EXHIBIT IS NOT INTENDED TO MEET THE REQUIREMENTS OF A CERTIFIED SURVEY AS DEFINED BY PUBLIC ACT 132 OF 1970, AS AMENDED, OR ANY OTHER APPLICABLE SURVEYING LAW WITHIN THE STATE OF MICHIGAN.

D.A. Parsell

01.31.2016

DANA A. PARSELL, P.S.
 MICHIGAN PROFESSIONAL SURVEYOR #51483

DATE:

PREPARED FOR:

NEXUS Gas Transmission, LLC



PREPARED BY:



4848 LOOP CENTRAL DR.
 Suite 100
 HOUSTON, TX, 77081
 PH. 713-977-7770

JOB NO.

22203

DATE:

01/15/2016

DRAWN:

DMB

APPROVED:

DP

SCALE:

1"=50'

EXHIBIT "A"-4

THE PROPERTY OF
 CHARTER TOWNSHIP OF YPSILANTI

SHEET

1 OF 2

DOC. NO.

22203-250-PSK-40202

DWG. NO.

MI-WA-119.0040

REV

0

EXHIBIT "A"-4

YPSILANTI TOWNSHIP, WASHTENAW COUNTY, MICHIGAN
 T 3 S, R 7 E : SECTION 13
 MICHIGAN SURVEY

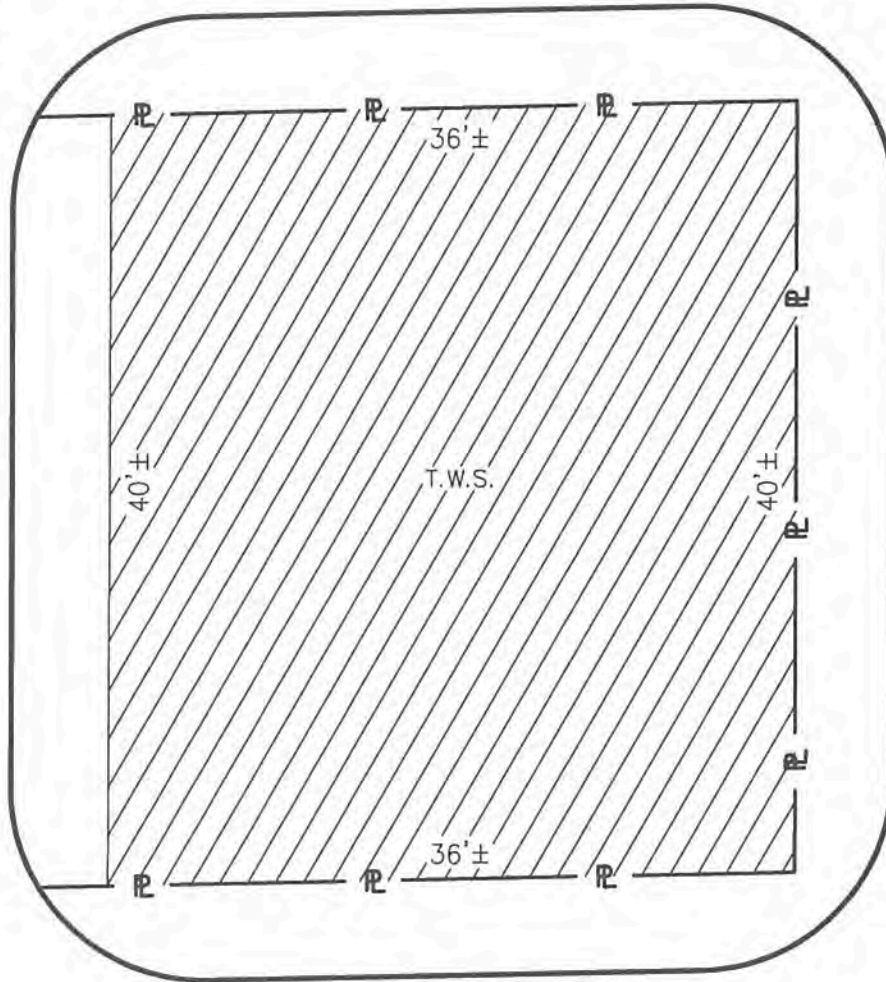

DETAIL "A"

N.T.S.

ISSUED FOR ACQUISITION - 01/28/2016

0

REVISIONS

PREPARED FOR:

NEXUS Gas
Transmission, LLC



PREPARED BY:



Universal Pegasus
INTERNATIONAL
A Subsidiary of Huntington Ingalls Industries
COA: Universal Enasco, Inc.

4848 LOOP CENTRAL DR.
Suite 100
HOUSTON, TX. 77081
PH. 713-977-7770

JOB NO.

22203

DATE:

01/15/2016

DRAWN:

DMB

APPROVED:

DP

SCALE:

N.T.S.

EXHIBIT "A"-4

THE PROPERTY OF
CHARTER TOWNSHIP OF YPSILANTI

SHEET

2 OF 2

DOC. NO.

22203-250-PSK-40202

DWG. NO.

MI-WA-119.0040

REV

0

EXHIBIT "A" - 5

YPSILANTI TOWNSHIP, WASHTENAW COUNTY, MICHIGAN
T 3 S, R 7 E : SECTION 13
MICHIGAN SURVEY

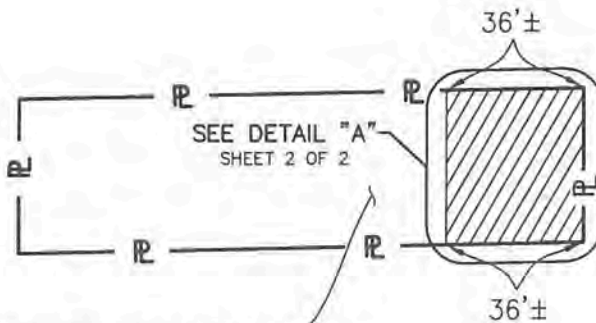
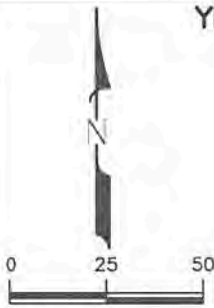

TRACT NO. MI-WA-119.0050

CHARTER TOWNSHIP OF YPSILANTI
TAX ID NO. K-11-13-331-015

REVISIONS 0 ISSUED FOR ACQUISITION - 01/28/2016

SURVEYOR'S SEAL



PROP. TEMP. WORKSPACE (T.W.S.): 1,423 ± SQ. FT.

NOTES:

1. THE ACTUAL LOCATION OF THE NEW PERMANENT EASEMENT IS DETERMINED BY THE FIRST PIPELINE AS INSTALLED.
2. ALL BEARINGS AND DISTANCES (US SURVEY FEET) HEREIN ARE GRID AND BASED UPON THE UNIVERSAL TRANSVERSE MERCATOR PROJECTION, ZONE 17 NORTH (UTM17N), NORTH AMERICAN DATUM OF 1983 (NAD83 (2011)).
3. I HEREBY CERTIFY THAT THIS EASEMENT EXHIBIT IS NOT A BOUNDARY SURVEY OR CERTIFIED SURVEY AND WAS PREPARED UNDER MY DIRECT SUPERVISION FROM RECORD DATA ONLY. THE INFORMATION WITHIN THIS EXHIBIT IS NOT INTENDED TO MEET THE REQUIREMENTS OF A CERTIFIED SURVEY AS DEFINED BY PUBLIC ACT 132 OF 1970, AS AMENDED, OR ANY OTHER APPLICABLE SURVEYING LAW WITHIN THE STATE OF MICHIGAN.

D.A. Parsell

01.31.2016

DANA A. PARSELL, P.S.
MICHIGAN PROFESSIONAL SURVEYOR #51483

DATE:

PREPARED FOR:

NEXUS Gas
Transmission, LLC



PREPARED BY:



4848 LOOP CENTRAL DR.
Suite 100
HOUSTON, TX. 77081
PH. 713-977-7770

JOB NO.

22203

DATE:

01/15/2016

DRAWN:

DMB

APPROVED:

DP

SCALE:

1"=50'

EXHIBIT "A" - 5

THE PROPERTY OF
CHARTER TOWNSHIP OF YPSILANTI

SHEET
1 OF 2

DOC. NO.
22203-250-PSK-40203

DWG. NO.
MI-WA-119.0050

REV
0

EXHIBIT "A"- 5

YPSILANTI TOWNSHIP, WASHTENAW COUNTY, MICHIGAN
 T 3 S, R 7 E : SECTION 13
 MICHIGAN SURVEY

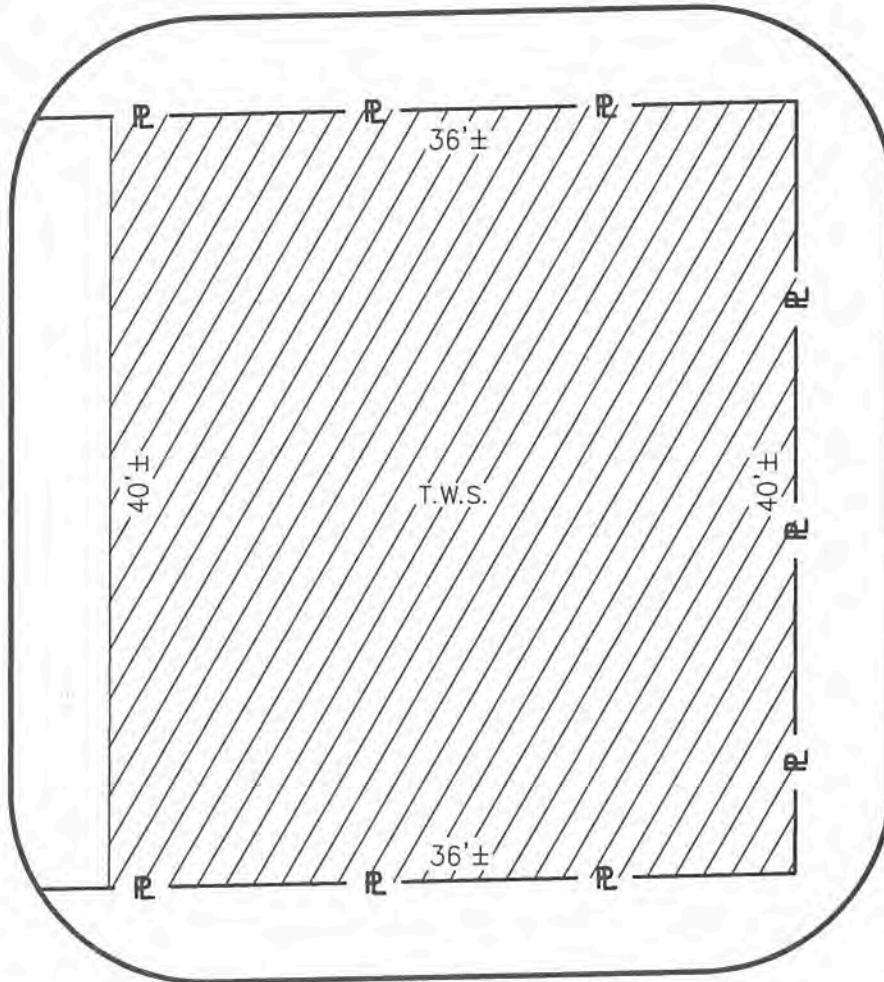

DETAIL "A"
 N.T.S.

REVISIONS 0 ISSUED FOR ACQUISITION - 01/28/2016

PREPARED FOR:

NEXUS Gas
 Transmission, LLC



PREPARED BY:



4848 LOOP CENTRAL DR.
 Suite 100
 HOUSTON, TX. 77081
 PH. 713-977-7770

JOB NO.

22203

DATE:

01/15/2016

DRAWN:

DMB

APPROVED:

DP

SCALE:

N.T.S.

EXHIBIT "A"- 5
 THE PROPERTY OF
 CHARTER TOWNSHIP OF YPSILANTI

SHEET
 2 OF 2

DOC. NO.
 22203-250-PSK-40203

DWG. NO.
 MI-WA-119.0050

REV
 0

EXHIBIT "A"-6

YPSILANTI TOWNSHIP, WASHTENAW COUNTY, MICHIGAN
T 3 S, R 7 E : PART OF SECTION 13
MICHIGAN SURVEY

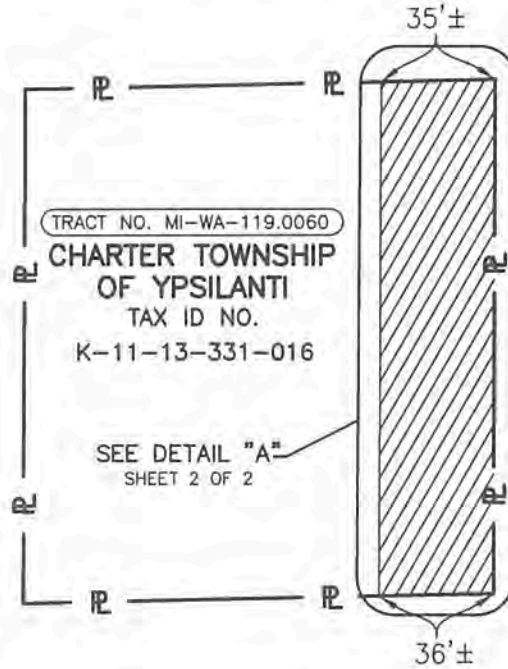
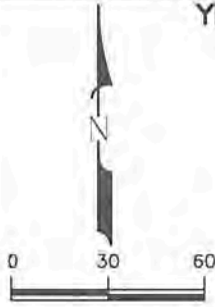

REVISIONS 0 ISSUED FOR ACQUISITION - 01/28/2016

SURVEYOR'S SEAL



PROP. TEMP. WORKSPACE (T.W.S.): 0.1 ± ACRE

NOTES:

1. THE ACTUAL LOCATION OF THE NEW PERMANENT EASEMENT IS DETERMINED BY THE FIRST PIPELINE AS INSTALLED.
2. ALL BEARINGS AND DISTANCES (US SURVEY FEET) HEREIN ARE GRID AND BASED UPON THE UNIVERSAL TRANSVERSE MERCATOR PROJECTION, ZONE 17 NORTH (UTM17N), NORTH AMERICAN DATUM OF 1983 (NAD83 (2011)).
3. I HEREBY CERTIFY THAT THIS EASEMENT EXHIBIT IS NOT A BOUNDARY SURVEY OR CERTIFIED SURVEY AND WAS PREPARED UNDER MY DIRECT SUPERVISION FROM RECORD DATA ONLY. THE INFORMATION WITHIN THIS EXHIBIT IS NOT INTENDED TO MEET THE REQUIREMENTS OF A CERTIFIED SURVEY AS DEFINED BY PUBLIC ACT 132 OF 1970, AS AMENDED, OR ANY OTHER APPLICABLE SURVEYING LAW WITHIN THE STATE OF MICHIGAN.

D.A.P.

01.31.2016

DANA A. PARSELL, P.S.
MICHIGAN PROFESSIONAL SURVEYOR #51483

DATE:

PREPARED FOR:

NEXUS Gas
Transmission, LLC



PREPARED BY:



4848 LOOP CENTRAL DR.
Suite 100
HOUSTON, TX, 77081
PH. 713-977-7770

JOB NO.

22203

DATE:

01/15/2016

DRAWN:

CE

APPROVED:

DP

SCALE:

1"=60'

SHEET

1 OF 2

DOC. NO.

22203-250-PSK-40204

DWG. NO.

MI-WA-119.0060

REV

0

EXHIBIT "A"-6

THE PROPERTY OF
CHARTER TOWNSHIP OF YPSILANTI

EXHIBIT "A"-6

YPSILANTI TOWNSHIP, WASHTENAW COUNTY, MICHIGAN
 T 3 S, R 7 E : PART OF SECTION 13
 MICHIGAN SURVEY

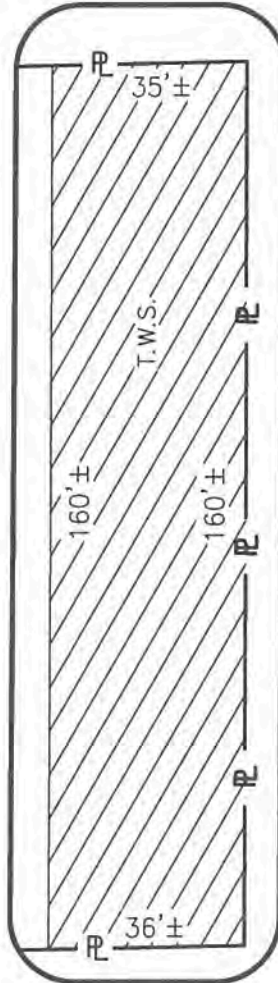

DETAIL "A"
 N.T.S.

REVISIONS 0 ISSUED FOR ACQUISITION - 01/28/2016



PREPARED FOR: NEXUS Gas Transmission, LLC 	PREPARED BY:  UniversalPegasus INTERNATIONAL <small>A Subsidiary of Huntington Ingalls Industries</small> COA: Universal Enesco, Inc. 4848 LOOP CENTRAL DR. Suite 100 HOUSTON, TX. 77081 PH. 713-977-7770	JOB NO. 22203	EXHIBIT "A"-6 THE PROPERTY OF CHARTER TOWNSHIP OF YPSILANTI		
		DATE: 01/15/2016 DRAWN: CE APPROVED: DP			

EXHIBIT "A" - 7

YPSILANTI TOWNSHIP, WASHTENAW COUNTY, MICHIGAN
T 3 S, R 7 E : PART OF SECTION SECTION 13
MICHIGAN SURVEY

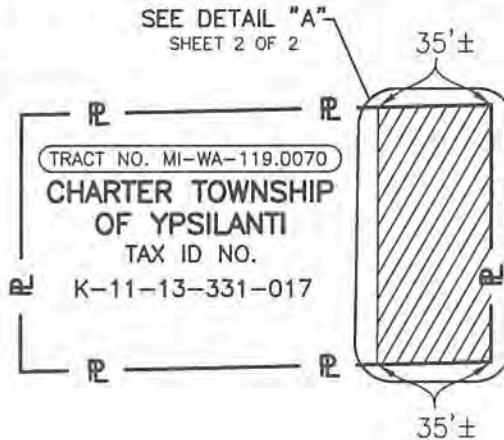
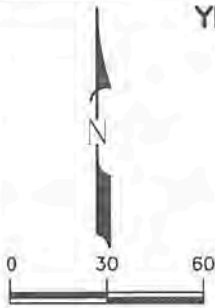

REVISIONS 0 ISSUED FOR ACQUISITION - 01/28/2016

SURVEYOR'S SEAL



PROP. TEMP. WORKSPACE (T.W.S.): 0.1 ± ACRE

NOTES:

1. THE ACTUAL LOCATION OF THE NEW PERMANENT EASEMENT IS DETERMINED BY THE FIRST PIPELINE AS INSTALLED.
2. ALL BEARINGS AND DISTANCES (US SURVEY FEET) HEREIN ARE GRID AND BASED UPON THE UNIVERSAL TRANSVERSE MERCATOR PROJECTION, ZONE 17 NORTH (UTM17N), NORTH AMERICAN DATUM OF 1983 (NAD83 (2011)).
3. I HEREBY CERTIFY THAT THIS EASEMENT EXHIBIT IS NOT A BOUNDARY SURVEY OR CERTIFIED SURVEY AND WAS PREPARED UNDER MY DIRECT SUPERVISION FROM RECORD DATA ONLY. THE INFORMATION WITHIN THIS EXHIBIT IS NOT INTENDED TO MEET THE REQUIREMENTS OF A CERTIFIED SURVEY AS DEFINED BY PUBLIC ACT 132 OF 1970, AS AMENDED, OR ANY OTHER APPLICABLE SURVEYING LAW WITHIN THE STATE OF MICHIGAN.

D.A. Parsell

01.31.2016

DANA A. PARSELL, P.S.
MICHIGAN PROFESSIONAL SURVEYOR #51483

DATE:

PREPARED FOR:

NEXUS Gas
Transmission, LLC



PREPARED BY:

Universal Pegasus
INTERNATIONAL
A Subsidiary of Huntington Ingalls Industries
COA: Universal Enasco, Inc.
4848 LOOP CENTRAL DR.
Suite 100
HOUSTON, TX. 77081
PH. 713-977-7770

JOB NO.

22203

DATE:

01/15/2016

DRAWN:

CE

APPROVED:

DP

SCALE:

1"=60'

SHEET

1 OF 2

DOC. NO.

22203-250-PSK-40205

DWG. NO.

MI-WA-119.0070

REV

0

EXHIBIT "A" - 7

THE PROPERTY OF
CHARTER TOWNSHIP OF YPSILANTI

EXHIBIT "A"-7

YPSILANTI TOWNSHIP, WASHTENAW COUNTY, MICHIGAN
 T 3 S, R 7 E : PART OF SECTION SECTION 13
 MICHIGAN SURVEY

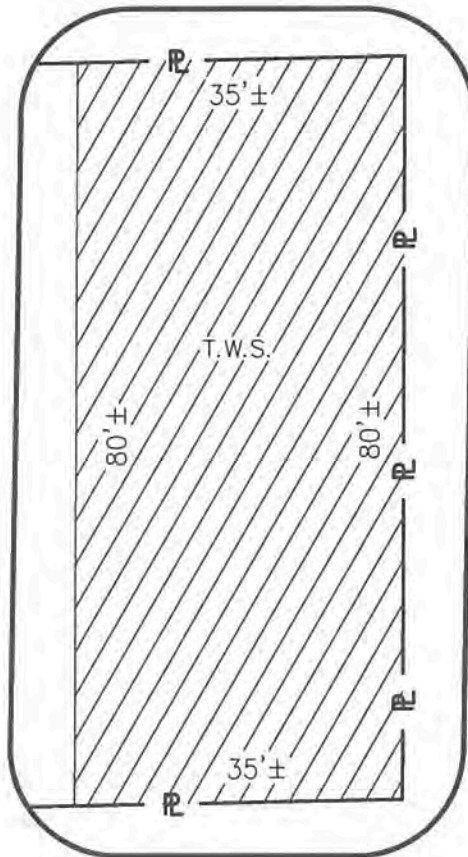

DETAIL "A"
 N.T.S.

0 ISSUED FOR ACQUISITION - 01/28/2016

REVISIONS



PREPARED FOR: NEXUS Gas Transmission, LLC 	PREPARED BY:  Universal Pegasus INTERNATIONAL <small>A Subsidiary of Huntington Ingalls Industries</small> COA: Universal Enasco, Inc. 4848 LOOP CENTRAL DR. Suite 100 HOUSTON, TX. 77081 PH. 713-977-7770	JOB NO. 22203	EXHIBIT "A"-7 THE PROPERTY OF CHARTER TOWNSHIP OF YPSILANTI		
		DATE: 01/15/2016 DRAWN: CE APPROVED: DP			
SCALE: N.T.S.		SHEET 2 OF 2	DOC. NO. 22203-250-PSK-40205	DWG. NO. MI-WA-119.0070	REV 0

EXHIBIT "A"-8

YPSILANTI TOWNSHIP, WASHTENAW COUNTY, MICHIGAN
 T 3 S, R 7 E : SECTION 13
 MICHIGAN SURVEY



SEE DETAIL "A"
 SHEET 2 OF 2

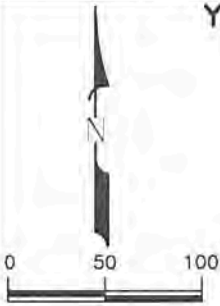
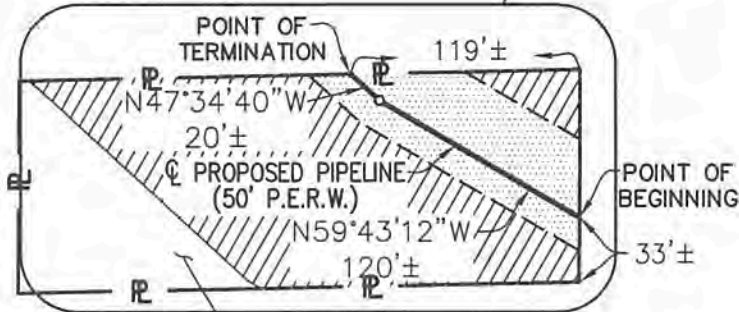

TRACT NO. MI-WA-122.0000

CHARTER TOWNSHIP
 OF YPSILANTI

TAX ID NO. K-11-13-331-001

REVISIONS 0 ISSUED FOR ACQUISITION - 01/28/2016

SURVEYOR'S SEAL



- PROP. PIPELINE: 140' ±
- - - - PROP. PERM. EASEMENT (P.E.R.W.): 0.1 ± ACRE
- ////// PROP. TEMP. WORKSPACE (T.W.S.): 0.4 ± ACRE

NOTES:

1. THE ACTUAL LOCATION OF THE NEW PERMANENT EASEMENT IS DETERMINED BY THE FIRST PIPELINE AS INSTALLED.
2. ALL BEARINGS AND DISTANCES (US SURVEY FEET) HEREIN ARE GRID AND BASED UPON THE UNIVERSAL TRANSVERSE MERCATOR PROJECTION, ZONE 17 NORTH (UTM17N), NORTH AMERICAN DATUM OF 1983 (NAD83 (2011)).
3. I HEREBY CERTIFY THAT THIS EASEMENT EXHIBIT IS NOT A BOUNDARY SURVEY OR CERTIFIED SURVEY AND WAS PREPARED UNDER MY DIRECT SUPERVISION FROM RECORD DATA ONLY. THE INFORMATION WITHIN THIS EXHIBIT IS NOT INTENDED TO MEET THE REQUIREMENTS OF A CERTIFIED SURVEY AS DEFINED BY PUBLIC ACT 132 OF 1970, AS AMENDED, OR ANY OTHER APPLICABLE SURVEYING LAW WITHIN THE STATE OF MICHIGAN.

D.A. Parsell

01.31.2016

DANA A. PARSELL, P.S.
 MICHIGAN PROFESSIONAL SURVEYOR #51483

DATE:

PREPARED FOR:

NEXUS Gas
 Transmission, LLC



PREPARED BY:

UniversalPegasus
 INTERNATIONAL
A Subsidiary of Huntington Ingalls Industries
 COA: Universal Enaco, Inc.

4848 LOOP CENTRAL DR.
 Suite 100
 HOUSTON, TX. 77081
 PH. 713-977-7770

JOB NO.

22203

DATE:

01/15/2016

DRAWN:

DCM

APPROVED:

DP

SCALE:

1"=100'

SHEET
 1 OF 2

DOC. NO.
 22203-250-PSK-40209

DWG. NO.
 MI-WA-122.0000

REV
 0

EXHIBIT "A"-8

THE PROPERTY OF
 CHARTER TOWNSHIP
 OF YPSILANTI

EXHIBIT "A"-8

YPSILANTI TOWNSHIP, WASHTENAW COUNTY, MICHIGAN
 T 3 S, R 7 E :SECTION 13
 MICHIGAN SURVEY

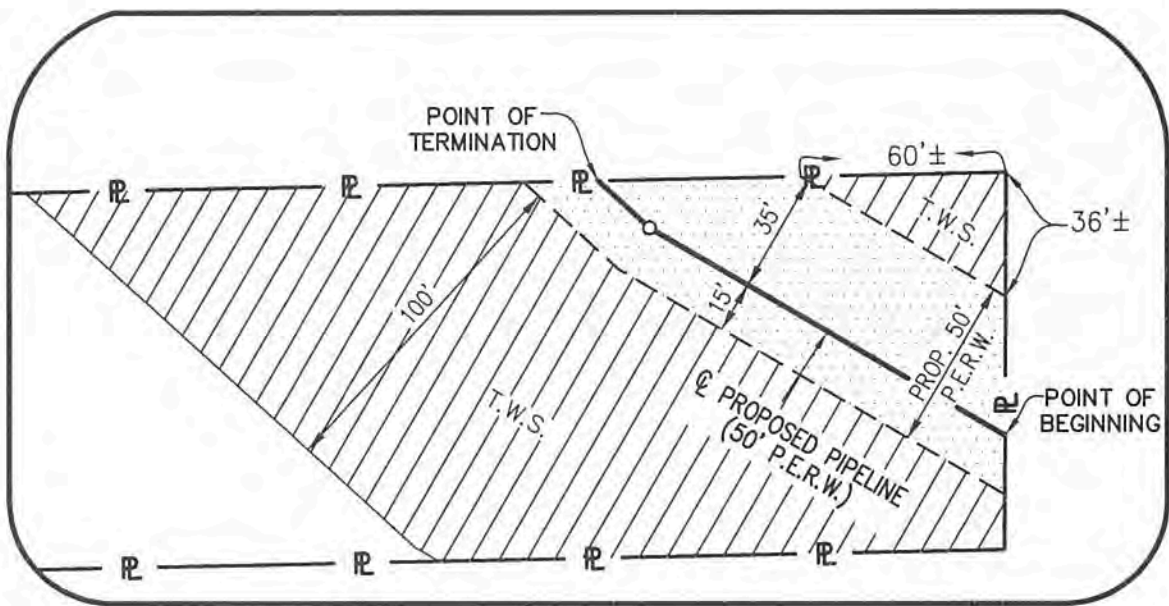

DETAIL "A"
 N.T.S.

REVISIONS 0 ISSUED FOR ACQUISITION - 01/28/2016

PREPARED FOR:

NEXUS Gas
 Transmission, LLC



PREPARED BY:



4848 LOOP CENTRAL DR.
 Suite 100
 HOUSTON, TX. 77081
 PH. 713-977-7770

JOB NO.

22203

DATE:

01/15/2016

DRAWN:

DCM

APPROVED:

DP

SCALE:

N.T.S.

SHEET
 2 OF 2

DOC. NO.
 22203-250-PSK-40209

DWG. NO.
 MI-WA-122.0000

REV
 0

EXHIBIT "A"-8

THE PROPERTY OF
 CHARTER TOWNSHIP
 OF YPSILANTI

EXHIBIT "A" - 9

YPSILANTI TOWNSHIP, WASHTENAW COUNTY, MICHIGAN
 PART OF LOTS 519 THRU LOTS 527
 & WEST 1/2 OF VACATED BEVERLY AVENUE
 WATSONIA PARK SUBDIVISION, T 3 S, R 7 E : SECTION 13
 MICHIGAN SURVEY

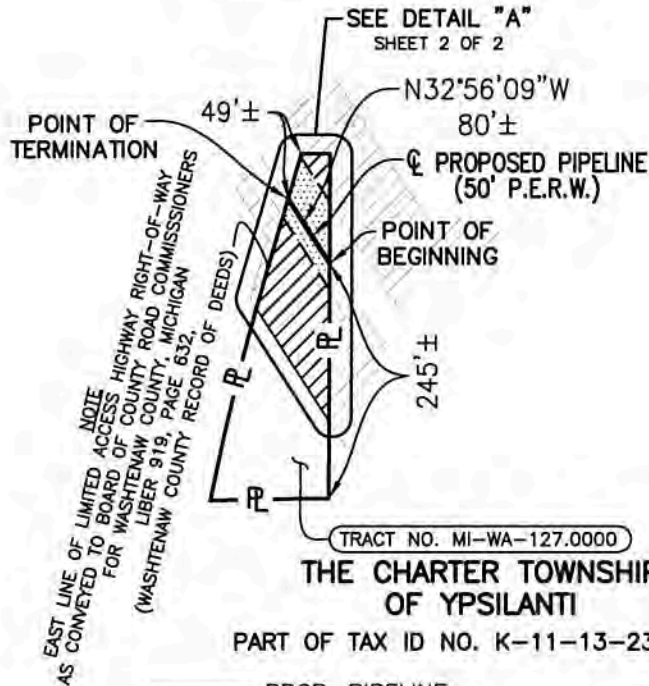
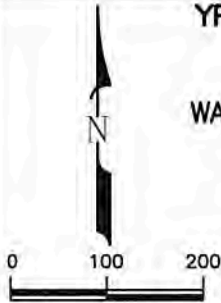

**THE CHARTER TOWNSHIP
 OF YPSILANTI**
 PART OF TAX ID NO. K-11-13-232-002

- PROP. PIPELINE: 80' ±
- PROP. PERM. EASEMENT (P.E.R.W.): 0.1 ± ACRE
- PROP. TEMP. WORKSPACE (T.W.S.): 0.2 ± ACRE

NOTES:

1. THE ACTUAL LOCATION OF THE NEW PERMANENT EASEMENT IS DETERMINED BY THE FIRST PIPELINE AS INSTALLED.
2. ALL BEARINGS AND DISTANCES (US SURVEY FEET) HEREIN ARE GRID AND BASED UPON THE UNIVERSAL TRANSVERSE MERCATOR PROJECTION, ZONE 17 NORTH (UTM17N), NORTH AMERICAN DATUM OF 1983 (NAD83 (2011)).
3. I HEREBY CERTIFY THAT THIS EASEMENT EXHIBIT IS NOT A BOUNDARY SURVEY OR CERTIFIED SURVEY AND WAS PREPARED UNDER MY DIRECT SUPERVISION FROM RECORD DATA ONLY. THE INFORMATION WITHIN THIS EXHIBIT IS NOT INTENDED TO MEET THE REQUIREMENTS OF A CERTIFIED SURVEY AS DEFINED BY PUBLIC ACT 132 OF 1970, AS AMENDED, OR ANY OTHER APPLICABLE SURVEYING LAW WITHIN THE STATE OF MICHIGAN.

D.A. Parsell 04.01.2016

 DANA A. PARSELL, P.S. DATE:
 MICHIGAN PROFESSIONAL SURVEYOR #51483

SURVEYOR'S SEAL



REVISIONS 0 ISSUED FOR ACQUISITION - 04/01/2016

PREPARED FOR:

NEXUS Gas Transmission, LLC



PREPARED BY:



4848 LOOP CENTRAL DR.
 Suite 100
 HOUSTON, TX. 77081
 PH. 713-977-7770

JOB NO.

22203

DATE:

03/16/2016

DRAWN:

LBJ

APPROVED:

DP

SCALE:

1"=200'

SHEET

1 OF 2

DOC. NO.

22203-250-PSK-40259

DWG. NO.

MI-WA-127.0000

REV

0

EXHIBIT "A" - 9

THE PROPERTY OF
 THE CHARTER
 TOWNSHIP OF YPSILANTI

EXHIBIT "A"-9

YPSILANTI TOWNSHIP, WASHTENAW COUNTY, MICHIGAN
 PART OF LOTS 519 THRU LOTS 527
 & WEST 1/2 OF VACATED BEVERLY AVENUE
 WATSONIA PARK SUBDIVISION, T 3 S, R 7 E : SECTION 13
 MICHIGAN SURVEY

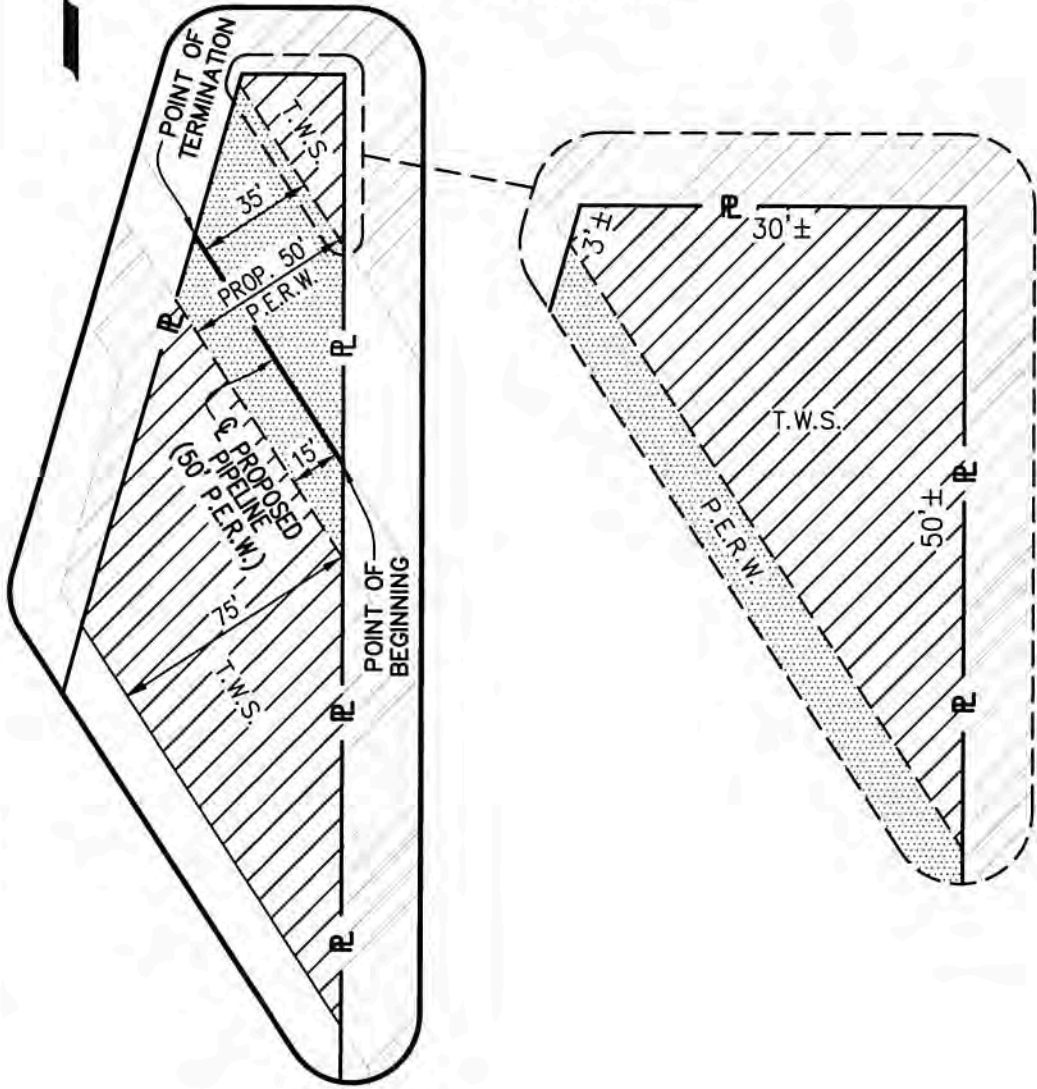

DETAIL "A"
 N.T.S.

REVISIONS 0 ISSUED FOR ACQUISITION - 04/01/2016

PREPARED FOR: NEXUS Gas Transmission, LLC 	PREPARED BY: Universal Pegasus INTERNATIONAL <small>A Subsidiary of Huntington Ingalls Industries</small> COA: Universal Ensco, Inc. 4848 LOOP CENTRAL DR. Suite 100 HOUSTON, TX. 77081 PH. 713-977-7770	JOB NO. 22203	EXHIBIT "A"-9 THE PROPERTY OF THE CHARTER TOWNSHIP OF YPSILANTI		
		DATE: 03/16/2016 DRAWN: LBJ APPROVED: DP SCALE: N.T.S.			

Supervisor
BRENDA L. STUMBO
Chair
KAREN LOVEJOY ROE
Treasurer
LARRY J. DOE
Trustees
JEAN HALL CURRIE
STAN ELDRIDGE
MIKE MARTIN
SCOTT MARTIN



Assessor's Office

7200 S. Huron River Drive
Ypsilanti, MI 48197
Phone: (734) 487-4927
Fax: (734) 484-5159

Charter Township of Ypsilanti

Letter of Agreement

November 23, 2016

Robert & Lavinia Glodeanu
415 Campbell Ave
Ypsilanti, MI 48197

Dear Mr. and Mrs. Glodeanu,

This letter (the "Agreement") summarizes the understanding of the agreement that we reached during our conversation on November 14, 2016. If this Agreement is acceptable to you, please sign below in the space designated for your signature.

The agreement is as follows:

1. Agreement

The following is agreed upon for the Purchase of Township Owned Property:

The property listed below will be purchased for the price of \$1,000 paid by certified check. The Property is to be combined with purchaser's adjacent vacant residential parcel on Hubbard Ave, parcel id K-11-21-180-006. This property will be used for development of a single family, owner occupied, residential property.

Parcel **K-11-21-180-005** described as:
Hubbard Ave- Vacant
Lots 122 & 123
Cadillac Heights Subdivision

2. Term

The term of this Agreement ("Term") will commence as of December 1, 2016 and will continue to be in effect for 6 months or until June 1, 2017, at which point it shall terminate, unless the Term is extended or terminated earlier in a written document signed by both parties.

Letter of Agreement- Continued

3. Closing

For the agreed upon sum of **\$1,000** paid in full by certified check, Ypsilanti Township agrees to sell the above described properties to you via the recording of a Quit Claim Deed in the name of Robert & Lavinia Glodeanu.

4. Termination

This agreement shall terminate upon the closing of the sale of the above property or the expiration of the Term after June 1, 2017.

If the above correctly expresses your understanding of the terms reached during the negotiations, please sign and date a copy of this Agreement and return the signed and dated Agreement to me.

Brenda L Stumbo, Supervisor
Charter Township of Ypsilanti
7200 S. Huron River Dr.
Ypsilanti, MI 48197

Karen Lovejoy Roe, Clerk
Charter Township of Ypsilanti
7200 S. Huron River Dr.
Ypsilanti, MI 48197

Notary Public, _____ County

My Commission Expires on _____

Accepted and agreed to on Nov. 23, 2016 by



Robert Glodeanu

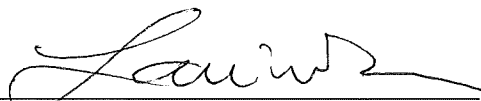

Lavinia Glodeanu
JANE E. CARR

NOTARY PUBLIC-STATE OF MICHIGAN
COUNTY OF WASHTENAW

My Commission Expires June 7, 2022

Acting in the County of Washtenaw Jane E. Carr

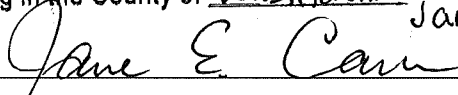

Notary Public, Washtenaw County

My Commission Expires on 6.7.22

QUIT CLAIM DEED

KNOW ALL MEN BY THESE PRESENTS, that the **Charter Township of Ypsilanti, a Michigan Municipal Corporation**, whose address is 7200 S. Huron River Drive, Ypsilanti, Michigan 48197, quitclaims to **Robert Glodeanu and Lavinia Glodeanu**, a married couple, whose address is 415 Campbell Ave., Ypsilanti, Michigan 48197, the following property located in the Township of Ypsilanti, County of Washtenaw, and State of Michigan and described as:

Lot 122 and 123
Cadillac Heights Subdivision

Parcel Id: K-11-21-180-005 (Hubbard Ave-vacant)

For the full consideration of One Thousand Dollars (\$1,000).

Property to be combined with purchaser's adjacent vacant residential property. The property will be used to develop a single family, owner occupied, residential property.

Dated this ____ day of _____ 2016

Charter Township of Ypsilanti, a Michigan
Municipal Corporation

By: _____
Brenda L. Stumbo, Supervisor

By: _____
Karen Lovejoy Roe, Clerk

Acknowledged before me in Washtenaw County, Michigan, on this ____ day of _____ 2016, by Brenda L. Stumbo, Supervisor, and Karen Lovejoy Roe, Clerk of Charter Township of Ypsilanti, a Michigan municipal corporation, on behalf of the corporation.

My Commission Expires:

Notary Public

Printed Name

_____ County, Michigan

Drafted By: Brian McCleery, Ypsilanti Township

7200 S. Huron River Dr., Ypsilanti, MI 48197

Supervisor
BRENDA L. STUMBO
Clerk
KAREN LOVEJOY ROE
Treasurer
LARRY J. DOE
Trustees
JEAN HALL CURRIE
STAN ELDRIDGE
MIKE MARTIN
SCOTT MARTIN



Assessor's Office

7200 S. Huron River Drive
Ypsilanti, MI 48197
Phone: (734) 487-4927
Fax: (734) 484-5159

Charter Township of Ypsilanti

Date: November 14, 2016

To: Karen Lovejoy Roe,
Ypsilanti Township Clerk

From: Brian McCleery,
Assistant Assessor

Subject: Approval to Enter into Negotiations to Sell Township owned property.

K-11-13-330-001 – State St

I am requesting approval to enter into negotiations to sell the above parcel currently owned by Ypsilanti Township. This property is a vacant parcel that Ypsilanti Township acquired in 1941 from MSHD as a group of multiple lots. Ypsilanti Township then sold the adjacent lots in 1988 but did not include this parcel, which consists of one 20 foot lot.

This parcel has been identified by our office as a lot to sell. It currently is being utilized, with surrounding parcels as a salvage and scrap center at 2574 State St and owned by A-1 Auto Salvage & Scrap Inc. As you can see from the aerial photographs, this parcel is partially fenced in by A-1 Auto.

I am requesting permission to contact A-1 Auto and offer to sell them this parcel.

The Assessor's Office will prepare a market valuation for the property in order to arrive at an estimated market value. I am requesting approval to start the negotiations at the appraised value and work with potential purchasers in order to arrive at a Fair Market Value for the properties.

This property has one platted lot with an overall dimensions of approximately 20' x 110'. If sold to the adjacent owner, the sales agreement would stipulate that the purchaser will combine the property with the adjacent parcel they own.

Attached you will find aerial photograph maps and a record card of the parcel. If you have any questions or need any information, please contacting me.

001
331-001

1701
-019
K-11-13-331-019

1703
-018
K-11-13-331-018

1704
-017
K-11-13-331-017

1706
-016
K-11-13-331-016

1709

1710
-015
K-11-13-331-015

1711
-014
K-11-13-331-014

1712
-013
K-11-13-331-013

1713
-012
K-11-13-331-012

1714
-011
K-11-13-331-011

1717



COOLIDGE



-002

WATSON AVE

-003

CADILLAC AVE

MAIN ST

IDE AVE

70.67 Ac.

WOODDALE AVE

BOMBER AVE

MCGREGOR AV

STATE ST

BEVERLY AVE

-001

-001
-002
-003
-004
-005
-006
-007
-008
-009
-010
-011

-019
-018
-017
-016
-015
-014
-013
-012
-011

-005
5.87 Ac.

-004
5.95 Ac.

-014

-003

-004

WOODDALE AVE

-005

-008

-006

-012

-010

COOLIDGE AVE

-001
-002
-003
-004

-017
-015
-013

-001
-002
-003

-008
-007

-001
-002
-003
-004

-001
-003
-008
100 Ac.

-002
-003
-004

-008
7.16 Ac.

IDE AVE

MAIN ST

LAVE

-007

Lot 116

001	1450
1701	-019
1703	-018
1704	-017
1706	-016
1709	-015
1710	-014
1711	-013
1712	-012
1713	-011
1717	

1449 1443 -001

-005

K -11-13-330-005

5.87 Ac.

-004

K -11-13-382-004

5.95 Ac.

1684

53	180	41.35
55	-014	
56-002	K -11-13-306-014	
57		
8		
9	K -11-13-306-005	
	-005	
13		
14	-006	
	K -11-13-306-006	
		K -11-13-306-012
16		
48	180	

COOLIDGE

Grantor	Grantee	Sale Price	Sale Date	Inst. Type	Terms of Sale	Liber & Page	Verified By	Prcnt. Trans.
M S H D	CHARTER TOWNSHIP OF YPSIL	0	02/20/1941	WD	NOT MARKET SALE	349/372		0.0

Property Address	Class: EXEMPT COUNTY, CI	Zoning: I3 IN	Building Permit(s)	Date	Number	Status
------------------	--------------------------	---------------	--------------------	------	--------	--------

STATE ST	School: VAN BUREN SCHOOL DISTRICT					
----------	-----------------------------------	--	--	--	--	--

	P.R.E. 0%					
--	-----------	--	--	--	--	--

Owner's Name/Address	MAP #: R 585 588 00					
----------------------	---------------------	--	--	--	--	--

CHARTER TWP OF YPSILANTI 7200 S HURON RIVER DR YPSILANTI MI 48197	2017 Est TCV Tentative					
---	------------------------	--	--	--	--	--

	Improved	X	Vacant	Land Value Estimates for Land Table 00999.YPSILANTI TOWNSHIP PROPERTY		
--	----------	---	--------	---	--	--

	Public Improvements			* Factors * 20 * 110		
--	---------------------	--	--	----------------------	--	--

				Description	Frontage	Depth	Front Depth	Rate %Adj.	Reason	Value
--	--	--	--	-------------	----------	-------	-------------	------------	--------	-------

					0.05 Acres			0	100	0
--	--	--	--	--	------------	--	--	---	-----	---

					0.05 Total Acres			Total Est. Land Value =		0
--	--	--	--	--	------------------	--	--	-------------------------	--	---

Tax Description	X	Dirt Road								
-----------------	---	-----------	--	--	--	--	--	--	--	--

YP#104-1123: LOT 1443 WATSONIA PARK SUBDIVISION.	X	Gravel Road								
--	---	-------------	--	--	--	--	--	--	--	--

Comments/Influences	X	Paved Road								
---------------------	---	------------	--	--	--	--	--	--	--	--

		Storm Sewer								
--	--	-------------	--	--	--	--	--	--	--	--

		Sidewalk								
--	--	----------	--	--	--	--	--	--	--	--

		Water								
--	--	-------	--	--	--	--	--	--	--	--

		Sewer								
--	--	-------	--	--	--	--	--	--	--	--

		Electric								
--	--	----------	--	--	--	--	--	--	--	--

		Gas								
--	--	-----	--	--	--	--	--	--	--	--

		Curb								
--	--	------	--	--	--	--	--	--	--	--

		Street Lights								
--	--	---------------	--	--	--	--	--	--	--	--

	X	Standard Utilities								
--	---	--------------------	--	--	--	--	--	--	--	--

		Underground Utils.								
--	--	--------------------	--	--	--	--	--	--	--	--

		Topography of Site								
--	--	--------------------	--	--	--	--	--	--	--	--

	X	Level								
--	---	-------	--	--	--	--	--	--	--	--

		Rolling								
--	--	---------	--	--	--	--	--	--	--	--

		Low								
--	--	-----	--	--	--	--	--	--	--	--

		High								
--	--	------	--	--	--	--	--	--	--	--

		Landscaped								
--	--	------------	--	--	--	--	--	--	--	--

		Swamp								
--	--	-------	--	--	--	--	--	--	--	--

		Wooded								
--	--	--------	--	--	--	--	--	--	--	--

		Pond								
--	--	------	--	--	--	--	--	--	--	--

		Waterfront								
--	--	------------	--	--	--	--	--	--	--	--

		Ravine								
--	--	--------	--	--	--	--	--	--	--	--

		Wetland								
--	--	---------	--	--	--	--	--	--	--	--

		Flood Plain								
--	--	-------------	--	--	--	--	--	--	--	--

			Year	Land Value	Building Value	Assessed Value	Board of Review	Tribunal/Other	Taxable Value
--	--	--	------	------------	----------------	----------------	-----------------	----------------	---------------

	Who	When	What	2017	EXEMPT	EXEMPT	EXEMPT		EXEMPT
--	-----	------	------	------	--------	--------	--------	--	--------

				2016	EXEMPT	EXEMPT	EXEMPT		EXEMPT
--	--	--	--	------	--------	--------	--------	--	--------

				2015	0	0	0		0
--	--	--	--	------	---	---	---	--	---

				2014	0	0	0		0
--	--	--	--	------	---	---	---	--	---

*** Information herein deemed reliable but not guaranteed***

The Equalizer. Copyright (c) 1999 - 2009. Licensed To: Township of Ypsilanti, County of Washtenaw, Michigan

Supervisor
BRENDA L. STUMBO
Clerk
KAREN LOVEJOY ROE
Treasurer
LARRY J. DOE
Trustees
JEAN HALL CURRIE
STAN ELDRIDGE
MIKE MARTIN
SCOTT MARTIN



Charter Township of Ypsilanti

Recreation Department/
Community Center

2025 East Clark Road
Ypsilanti, MI 48198
Phone: (734) 544-3807
Fax: (734) 544-3888
50 & Beyond: (734) 544-3838
www.ytown.org

Memorandum

TO: Karen Lovejoy-Roe, Ypsilanti Township Clerk
CC: Angie Verges, Recreation Services Manager
FROM: Debbie Aue
DATE: December 1, 2016
RE: Request to accept the Helen McCalla Foundation Grant

Please find attached the letter of acceptance for a \$6992.97 grant from the Helen McCalla Trust Foundation. The funds will be used to renovate an existing racquet ball court into a fitness room. It includes renovation cost and some new equipment.

I am asking that permission be given to Deborah Aue to accept this grant. The grant requires the letter be returned within 14 days with the check being dispersed on December 30, 2016.

EBY CONNER SMILLIE & BOURQUE, PLLC

ATTORNEYS AND COUNSELORS
320 MILLER AVENUE, SUITE 190
ANN ARBOR, MICHIGAN 48103-3385

TELEPHONE (734) 769-2691
FACSIMILE (734) 769-2702

OF COUNSEL:
CLAN CRAWFORD, JR.

PAT D. CONNER
MARK J. EBY
KEITH O. SMILLIE
THOMAS B. BOURQUE

Email: ksmillie@aol.com

November 28, 2016

Deborah Aue, Senior Adult Coordinator
Ypsilanti Township Senior Program
2025 East Clark Road
Ypsilanti, Michigan 48198

RE: Helen McCalla Trust

Dear Ms. Aue:

I represent the Trustees of the Helen McCalla Trust. My clients have reviewed your proposal dated September 13, 2016 for a distribution from the Trust. Your organization has been chosen as a recipient of a distribution from the Trust in the amount of \$6,992.97.

This distribution would come upon the condition that your organization use and expend the funds for the limited purpose described in paragraph C. of the attached Agreement. Please review this Agreement and if the terms are acceptable, have it signed by the person in your organization who has the authority for this purpose. Then return it to me within 14 days of the date of this letter. My client then intends to make the distribution before December 31, 2016.

Very truly yours,

EBY CONNER SMILLIE
& BOURQUE, PLLC



Keith O. Smillie

KOS:sf

Enclosures

Cc: Caroline Chipman (w/o enclosures)

(S:\Kos\McCalla Trust\2016 Distribution\Correspondence\2016 Distribution Letter - Ypsi Twnshp 11-28-2016.doc)

AGREEMENT

Effective Date: November 14, 2016

Donor: The Helen McCalla Trust
 c/o Keith O. Smillie Attorney
 320 Miller Ave., Suite 190
 Ann Arbor MI 48103

Donee: Ypsilanti Township Senior Program
 2025 East Clark Road
 Ypsilanti, Michigan 48198

Proposal Date: September 13, 2016
Distribution: \$6,992.97

PREMISES

A) Donor is a charitable foundation qualified by the Internal Revenue Service under Section 501(c)(3) of the Internal Revenue Code.

B) Under the terms of the trust and as required to maintain its charitable foundation status, Donor is to make annual distributions to recipients who meet certain qualifications and who agree to use that distribution for certain limited purposes. The limited purposes as stated in the trust are "for permanent or semi-permanent buildings and/or equipment benefitting elderly persons and/or handicapped children and not for any specific individuals or operational expenses."

C) Donee has submitted a proposal to the Donor for use of a distribution from Donor. That proposal has been approved. The approved proposal is for the purchase of the following equipment:

Renovate Racquet Ball Court into work out room \$6,992.97

(the "Approved Proposal").

D) Donee has been chosen by Donor as a recipient for the tax year ending December 31, 2015, of a distribution from the trust, which distribution is being made in the calendar year 2016 and which is in the amount described above. (the "Distribution")

E) Donee has agreed to accept the Distribution upon the terms and conditions as stated herein.

NOW THEREFORE, in consideration for the payment to Donee of the Distribution, Donee agrees to use and expend the Distribution for the limited purposes described in the Approved Proposal. After the expenditures have been completed, Donee shall submit to Donor's counsel at the above address, a summary of Donee's expenditure of the Distribution with copies of cancelled checks.

DONOR:
Helen McCalla Trust

DONEE:
Ypsilanti Township Senior Program

By: Caroline Chipman, Vice President
KeyBank, National Association, Co-Trustee

By: Deborah Aue
Its: Senior Adult Coordinator

By: James McGuire, Co-Trustee

Supervisor
BRENDA L. STUMBO
Clerk
KAREN LOVEJOY ROE
Treasurer
LARRY J. DOE
Trustees
JEAN HALL CURRIE
STAN ELDRIDGE
MIKE MARTIN
SCOTT MARTIN



Charter Township of Ypsilanti

**Recreation Department/
Community Center**

2025 East Clark Road
Ypsilanti, MI 48198
Phone: (734) 544-3807
Fax: (734) 544-3888
50 & Beyond: (734) 544-3838
www.ytown.org

Memorandum

TO: Brenda Stumbo, Ypsilanti Township Supervisor
FROM: Angela Verges, Recreation Services Manager
CC: Karen Lovejoy-Roe, Ypsilanti Township Clerk
DATE: December 2, 2016
RE: Grant from Helen McCalla Trust

This memo is in support of the grant that our 50 & Beyond program has been chosen as a recipient to receive. This is a grant that our Senior Coordinator applied for and has received multiple times for various projects.

The grant is an award from the *Helen McCalla Trust* in the amount of \$6,992.97. The funds will be used to repurpose one of the racquetball courts at the Recreation Department in an effort to increase revenue.

Please place this item on the agenda for the December 6, 2016 Board meeting for consideration of approval. I will be in attendance at the meeting to answer any questions.

Supervisor
BRENDA L. STUMBO
Clerk
KAREN LOVEJOY ROE
Treasurer
LARRY J. DOE
Trustees
JEAN HALL CURRIE
STAN ELDRIDGE
MIKE MARTIN
SCOTT MARTIN



Recreation Department/
Community Center

2025 East Clark Road
Ypsilanti, MI 48198
Phone: (734) 544-3807
Fax: (734) 544-3888
50 & Beyond: (734) 544-3838
www.ytown.org

Charter Township of Ypsilanti

September 13, 2016

Dear Mr. Smillie;

This request is in response to the Helen McCalla Trust. Our Recreation Department is applying for a grant to renovate a current racquet ball court into a fitness workout room and replace a tile floor in one of our rooms with a "dance" floor. We are submitting this request in 2 parts and hope that you will decide to fund them both.

The "50 & Beyond" older adult program is located in the Ypsilanti Township Community Center and is managed by the Ypsilanti Township Recreation Department. The program is 100% funded by the township; however, many activities, equipment, and upgrades are funded through grants and our annual fundraiser craft fair. The township is fully committed to funding and supporting this vital program and service for our community. We have a membership of over 1,100 which has formed their own board. They maintain a separate checking account for their travel and activity programs. If awarded, the grant will be administered by the Township following our standard accounting procedures.

The geographic service area of our program includes all the surrounding cities and townships in Washtenaw County. We don't have a residency requirement to participate in our programs. Our membership is socially and economically diverse. Many of our members could never afford to join a gym or to pay for exercise classes. We consistently have 1,000+ registered members that use our facility annually. We offer fitness classes everyday Monday through Friday. In the past, we purchased three recumbent bikes and 2 treadmills with money provided by Helen McCalla Trust. Our membership uses this equipment daily. The popularity of this cardiovascular equipment has grown (especially with the male population) over the past couple of years. Our equipment is currently located in a room that also houses our pool tables. Due to the popularity of both activities the room can get very crowded. We believe converting a racquet ball court into a workout room and moving the exercise equipment there will allow more seniors to use the equipment. We have also heard from our female population that they feel uncomfortable using the equipment while the pool players are in the room. The new workout room would give them the privacy they need while exercising. To complete this project we are requesting funds to purchase some hand weights and racks.

The renovation portion of this project will consist of the following: (see attached estimates)

- Contract to upgrade the current entrance door to ADA standards adding a lock system to control the use of the room for our 50 & over population. \$1976.69
- Purchase and Install mirrors on the short wall \$1500.00
- Purchase Kettle Bell set with rack \$274.55
- Purchase Dumbbell Set with Rack \$372.23
- Purchase and Install acoustical panels for sound to control the echo \$1477.50

- Labor to have Township staff move the existing equipment and set up the room
\$960.00 (16 hrs x 2 people x \$30hr)

Total estimated cost of this project is \$6992.97

Part two of our request is to renovate the floor in room 303. Currently this room is used for spill over dance classes as it has mirrors on one wall and a portable dance bar. The problem is the current floor tile is dangerous for dancers in tap shoes. Recently our membership has seen an increase of people that are still working during the day. These members have inquired about evening dance classes similar to what is offered during our daytime hours. The problem we face is the recreation dance program is very successful and the dance studio is completely booked with youth classes. By converting this room into a more suitable environment for our older dancer we plan to open up evening dance classes for our 50 & Beyond members. There are several ways to do this project but in our research we feel this choice is the most economical with long-term benefits. We did research an actual hardwood floor system but the maintenance on this type of floor will be costly as the years go on.

- Rosco Arabesque Dance Floor \$2644.00
- Seam tape \$219.20
- Professional floor cleaner (enough for the year) \$234.00
- Epoxy Adhesive \$449.40
- Misc. shipping charges \$200.00
- Subfloor materials \$128.88
- Liquid nails \$51.98
- Labor to have township staff install \$1440.00 (24hr x 2 staff x \$30)

Total estimated cost for this project is \$5367.46

In closing, as the boomer population continues to age, the need for physical fitness and social programs will be even more in demand. Our program has been growing over the past several years. With these additions, we will continue to grow and attract the NEW senior. Washtenaw County has one of the largest senior populations in the state of Michigan. 10.8% of Washtenaw County residents are ages 60-74, and 4.5 % are 75 and over which totals 52,658 people. By the year 2040 the experts estimate those numbers will jump to 14.9% ages 60-74 and 13.1% age 75 and over which is a total of 108,129 people. With your help we can continue to offer our older adult population affordable (or free) opportunities to stay active and healthy; both, physically and socially, through their later years of life.

We ask that you consider funding both projects. We have included our current newsletter for our program to show you all of the wonderful programs we offer. Thank you for this opportunity and we look forward to working with your foundation in the future.

Deborah K Aue
Senior Adult Coordinator
Ypsilanti Township 50 & Beyond Program
2025 E. Clark, Ypsilanti, MI 48198
Phone: 734-544-3838 email: daue@ytown.org

Ypsilanti Township Board of Trustees

Brenda Stumbo, Supervisor
Karen Lovejoy-Roe, Clerk
Larry Doe, Treasurer
Jean Hall Currie, Trustee
Stan Eldridge, Trustee
Mike Martin, Trustee
Scott Martin, Trustee

Summary of request:

Project 1: Renovate a racquet ball court into a workout room \$6992.97

Project 2: replace a tile floor with a “dance” floor to create a safe classroom for older dance students. \$5367.46

Total to fund both projects: \$12,360.43

Resolution 2016-60

RESOLUTION TO ADOPT THE ANNUAL EXEMPTION OPTION AS SET FORTH IN 2011 PUBLIC ACT 152, THE PUBLICLY FUNDED HEALTH INSURANCE CONTRIBUTION ACT

WHEREAS, 2011 Public Act 152 (the “Act”) was passed by the State Legislature and signed by the Governor on September 24, 2011;

WHEREAS, the Act contains three options for complying with the requirements of the Act;

WHEREAS, the three options are as follows:

- 1) Section 3 - “Hard Caps” Option - limits a public employer’s total annual health care costs for employees based on coverage levels, as defined in the Act;
- 2) Section 4 - “80%/20%” Option - limits a public employer’s share of total annual health care costs to not more than 80%. This option requires an annual majority vote of the governing body;
- 3) Section 8 - “Exemption” Option - a local unit of government, as defined in the Act, may exempt itself from the requirements of the Act by an annual 2/3 vote of the governing body;

WHEREAS, the Charter Township of Ypsilanti Board of Trustees has decided to adopt the annual Exemption option as its choice of compliance under the Act;

NOW, THEREFORE, BE IT RESOLVED the Charter Township of Ypsilanti Board of Trustees of the Charter Township of Ypsilanti elects to comply with the requirements of 2011 Public Act 152, the Publicly Funded Health Insurance Contribution Act, by adopting the annual Exemption option for the medical benefit plan coverage year January 1, 2017 through December 31, 2017.

Supervisor
BRENDA L. STUMBO
Clerk
KAREN LOVEJOY ROE
Treasurer
LARRY J. DOE
Trustees
STAN ELDRIDGE
HEATHER JARRELL ROE
MONICA ROSS WILLIAMS
JIMMIE WILSON JR.



Accounting Dept

7200 S. Huron River Drive
Ypsilanti, MI 48197
Phone: (734) 484-3702
Fax: (734) 484-5154
www.ytown.org

To: Karen Lovejoy Roe, Clerk

From: Javonna Neel, Accounting Director

Date: November 30, 2016

RE: Request Resolution for an “Exemption Option” for Publicly Funded Health Insurance under Public Act 152.

The Township is to comply with an option for health care cost under Public Act 152. In the past, the Board motioned to lift the “Hard Cap” option and elect the “Exemption Option.” This option allows the Township to set the amount of employee contributions towards health care insurance. The employee annual contribution is currently \$1,800 (\$75 per pay for 24 pays) unless stated otherwise in their contracts.

We are required to have annual Board approval for the health care insurance option. This is for the health insurance coverage from January 1, 2017 through December 31, 2017. We have budgeted for the employees to contribute the same amount of \$1,800 for 2017. The 2017 increase for Blue Cross Blue Shield was .16%.



STATE OF MICHIGAN
DEPARTMENT OF TREASURY
LANSING

RICK SNYDER
GOVERNOR

NICK A. KHOURI
STATE TREASURER

September 20, 2016

**PUBLIC EMPLOYER CONTRIBUTIONS TO MEDICAL BENEFIT PLANS
ANNUAL COST LIMITATIONS – CALENDAR YEAR 2017**

For a medical benefit plan coverage year beginning on or after January 1, 2012, MCL 15.563, as amended by 2013 Public Act 270, sets a limit on the amount that a public employer may contribute to a medical benefit plan.

For medical benefit plan coverage years beginning on or after January 1, 2013, MCL 15.563 provides that the dollar amounts that are multiplied by the number of employees with each coverage type be adjusted annually. Specifically, the dollar amounts shall be adjusted, by October 1 of each year, by the change in the medical care component of the United States consumer price index for the most recent 12-month period for which data are available. For calendar year 2016, the limit on the amount that a public employer may contribute to a medical benefit plan was set to the sum of the following:

- \$ 6,142.11 times the number of employees and elected public officials with single-person coverage
- \$12,845.04 times the number of employees and elected public officials with individual-and-spouse coverage or individual-plus-1-nonspouse-dependent coverage
- \$16,751.23 times the number of employees and elected public officials with family coverage.

The limits for 2017 equal the 2016 limits increased by **3.3 percent**. The 3.3 percent is the percentage change in the medical care component from the period September 2014-August 2015 to the period September 2015-August 2016.

Thus, for medical benefit plan coverage years beginning on or after January 1, 2017, the limit on the amount that a public employer may contribute to a medical benefit plan equals the sum of the following:

- **\$ 6,344.80** times the number of employees and elected public officials with single-person coverage
- **\$13,268.93** times the number of employees and elected public officials with individual-and-spouse coverage or individual-plus-1-nonspouse-dependent coverage
- **\$17,304.02** times the number of employees and elected public officials with family coverage.

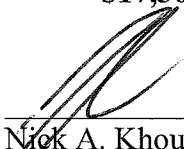

Nick A. Khouri
State Treasurer

September 20, 2016

**CHARTER TOWNSHIP OF YPSILANTI
Resolution No. 2016-61**

**ADOPTION OF REGULAR BOARD MEETING DATES
FOR THE 2017 CALENDAR YEAR**

NOW THEREFORE, BE IT RESOLVED that the attached schedule of dates and times be adopted for the Charter Township of Ypsilanti for the 2017 calendar year.

**CHARTER TOWNSHIP OF YPSILANTI
BOARD OF TRUSTEES**

SCHEDULE OF MEETINGS FOR 2017

Work Session 5:00 p.m. Civic Center Board Room	Regular Meeting 7:00 p.m. Civic Center Board Room
--	---

In 2017, the Township Board will meet on the 1st and 3rd Tuesday of each month in February, March, April, May, October, November and December and on the 3rd Tuesday of each month in January, June, July, August, and September.

Tuesday January 17, 2017

Tuesday February 7, 2017
Tuesday February 21, 2017

Tuesday March 7, 2017
Tuesday March 21, 2017

Tuesday April 4, 2017
Tuesday April 18, 2017

Tuesday May 2, 2017
Tuesday May 16, 2017

Tuesday June 20, 2017*

Tuesday July 18, 2017*

Tuesday August 15, 2017*

Tuesday September 19, 2017*

Tuesday October 3, 2017
Tuesday October 17, 2017

Tuesday November 7, 2017
Tuesday November 21, 2017

Tuesday December 5, 2017
Tuesday December 19, 2017

All meetings are held at the Ypsilanti Township Civic Center Building, 7200 S. Huron River Drive, Ypsilanti Township

Special Meetings may be called with 24-hour notification.

Pre-approval of Statements and Checks is authorized when no Board Meeting is held, with formal approval at the next regularly scheduled meeting, contingent on Board Members review and no objection.

*Board members should plan to reserve the first Tuesday of June, July, August and September in case a Special Meeting needs to be scheduled.

CHARTER TOWNSHIP OF YPSILANTI

RESOLUTION NO. 2016 - 62

ADOPTION OF ROBERT'S RULES OF ORDER

NOW THEREFORE, BE IT RESOLVED that Robert's Rules of Order shall be adopted by the Charter Township of Ypsilanti Board of Trustees for the 2017 calendar year.

CHARTER TOWNSHIP OF YPSILANTI

RESOLUTION NO. 2016-63

**DESIGNATION OF DEPOSITORIES
FOR 2017**

NOW THEREFORE, BE IT RESOLVED that First Merit Commercial and Savings Bank, Bank of Ann Arbor-Ypsilanti Office, Comerica Bank, Charter One, Ann Arbor State Bank, Fifth Third Bank, Chase Bank, P&C Bank, United Bank & Trust, Fidelity Bank, Huntington National Bank, Key Bank and TCF Bank and their successors be designated depositories for all Charter Township of Ypsilanti funds and securities for the 2017 calendar year.

CHARTER TOWNSHIP OF YPSILANTI

RESOLUTION NO. 2016-64

DESIGNATION OF NEWSPAPER OF CIRCULATION

NOW THEREFORE, BE IT RESOLVED that Washtenaw Legal and AnnArbor.com be designated as the newspapers of general circulation for the Charter Township of Ypsilanti advertisements and publications for the 2017 calendar year.

2017 ANNUAL LIST OF CONTRACTS AND RENEWALS

VENDOR/FIRM	DESCRIPTION
360 Service	Printing & mailing assessment notices & Pers. Prop.
Abby Door	Garage Doors
Adobe	Creative Cloud Subscription
Admin Arsenal	PDQ Software
A.F. Smith	Electrical Work
Air Source One	Breathing Air Compressor Maintenance
Alienvault	Network IDS Systems
Alternative Computer Technology, Inc.	Sophos Computer Security Software
Ann Arbor Audio	Board Room Sound System
Ann Arbor SPARK Dues	
Ann Arbor SPARK East Dues	
APEX	Assessing Drawing Software
Apollo Fire Equipment	
Applied Imaging	Printer Repair and Maintenance
ASAP	DOT Random Screens
ASC	
ASCAP	Phone Music
Ascend	Health Care Agent
AT&T	Voice/Data Communication Services
Automatic Irrigation Supply	Green Oaks Irrigation System – Rain Bird
Badger	Chipper Parts
Bandit	Chipper Parts
Barr Engineering	Hydro Station
B & C Painting	Paint and Graffiti Removal
Bell Tire	MI Deals Goodyear Dealer
Biddle Consulting Group	OPAC HR Testing Software
Blue Cross/Blue Shield of Michigan	Employee Health Care
Bresser's	
BS&A	Government Software Apps
Budget Towing	Vehicle Towing
Butzel Long	Labor Attorney
Carlisle Wortman Assoc., Inc.	
Carter & Burgess	Structural Engineer
CDWG	Microsoft Enterprise Agreement
Centron Data Services	Printing & mailing assessment notices & Personal Property
Choice Strategies	Employee Medical/Dependent Reimbursement – Benny Card
Cincinnati Time	Time Clocks
Cintas	First Aid Supplies
Clear Rate Communications	Telephone Service
Code42	Online Backup Services
Cognito LLC	Online Forms
Comcast	Internet Services
Comodo	Website Security Scanning
Conference of Western Wayne Firefighter Testing Program	Firefighter Testing Program
Conti	Cameras/Video
Controlled Power	U.P.S. (Uninterruptible Power Supply) Maintenance, Fire Dept.
D & B Power Associates, Inc.	UPS Maintenance
Delta Dental	Employee Dental Services
DTE Energy	Generator Maintenance
D J Conneley	Boiler Maintenance
Doan Construction	Sidewalk Repair Contractor and Engineer
Duo	Two Factor Authentication
DynDNS	DNS Services
Ed's Garage	Vehicle Repair
Election Systems & Software (ES&S)	Tabulator and AutoMark Maintenance Contract
Elsitech.com	Remote ScreenShare
EMPCO, Inc.	Fire Dept. Promotional Testing
ESRI	GIS Software Maintenance
Fiber Link Inc.	Miss Dig Management
Fire Findings	
Fire Safety 2000	
Fotolia.com	
FSCI	Stock Images

2017 Annual Contracts and Renewals

Page 2

Gabriel Roeder Smith & Company

Garan Lucow

GCSI

GFI Software

~~Godaddy.com~~

GolfNow

Google

Governmental Business Systems

Governor Computer

Grainger

Guardian Alarm

Hastings Air Energy Control

Honeywell

Hootsuite

Huron River Watershed Council Dues

Huron Valley Cabling

IBM

Int. Assoc. of Arson Invest

Imperva

International Code Council

Intern. Fire Chief's Assoc.

JAMAR Technologies

JTW Pipes, LLC

~~Kenica Albin~~

~~Langworthy, Strader & LeBlanc~~

Lastpass

Linode

Lighting Supply

Logisoft

Looking Good Lawns

MAP (Michigan Ability Partners)

Maps by Wagner

Marc Dutton Irrigation, Inc

Marketplace Solutions of Ohio, Inc.

Margolis Nursery

MASA

McLain & Winters

Meals on Wheels

Medtronic/Physio-Control

Merit.edu

MERS

Michigan Assessor Association

MI Association of Fire Chiefs

MiGMIS

Michigan Association of Planning (MAP)

Michigan CAT

Michigan Fire Inspector's Society

Michigan Fireman's Association

Michigan Municipal League

(MRPA)Michigan Recreation & Park Assoc.

Michigan Township Association Dues

Microsoft

Miracle Midwest

Monitis.com

Munetrix

National Fire Protection Association

Netwrix Corporation

Niswander LLC

O'Bryan's Lock & Key

OHM Engineering

Parkway Services

Parson's Brinkerhoff

Pencura

Pitney Bowes

Play Enviro

Playworld Midstates

PNC

PSLZ

Actuary Company

Lobbyist Firm

Patch Management Software

~~Web Server SSL Certs~~

Golf Course Management Software

Google Apps

Election Equipment & Supplies

Printer Repairs

Industrial Equipment

Security Alarm & Door Access System

Plymovent System Preventive Maintenance, Fire Dept.

HVAC – RSD

Social Media Manager Services

Structured Network Wiring

Maas360 Mobile Device Management

Webserver Application Firewall

State Building Code Books/Software

Traffic Survey Equipment

Plumber

~~Copier Maintenance~~

Password Management

Township Web Host

Bulbs, Ballasts, Lighting Supplies

Sophos Software/Firewall Software

Ordinance Mowing

Roadside Cleanup

Police/Fire/Elections/Residential Services Maps

Comm. Center Ball Field Irrigation Repairs

Trees and Landscaping

Softball purchase for adult programs at Rec. Dept.

Township Attorneys

Zimbra Maintenance

Employee Retirement System

Dues for Assessor Office

Michigan Governmental IT Professionals

C.E.D. training, reference etc.

Fire Truck Repairs, Compost Equipment Supplier/Repairs

Insurance

Per Art S.

Clerk's Office

Microsoft Licensing

Playscape Equipment for Specific Parks

External Network Monitoring

Web support – Dashboard & Citizen's Guide

Event Log Management

Locksmith

Port-A-John Rental

Playscape Equipment

Postage Machine

Playscape Equipment for Specific Parks

Playscape Equipment for Specific Parks

Employer Portion of Fire Dept. Pension

Auditors/David Williamson CPA

2017 Annual Contracts and Renewals

Page 3

Printing Systems
Professional Tree Service
QPS Printing
Q-Star Technology
Ricoh

Screenconnect Software, LLC

SEMCOG

SE Michigan Fire Chief's Assoc

~~Schneider Electric~~

Senior Nutrition Lease

Shrader Tire & Oil

Sinclair Recreation, LLC-Gametime

SiteOne Landscape Supply, LLC

Spartan Distributors

Spears Fire & Safety

~~Spectersoft~~

Spicer Group

Spok

Standard Insurance

Stantec

State of Michigan

Stormwater Management Services, LLC

Superior Diesel

Tetra Tech

Thomson Reuters

Total Fitness

Ulliance

Valentine Tree Service

Vanguard

Veriato

Verizon

Vermont Systems

V & J Cement Contractors

VMWare

Vision Service Plans (VSP)

Vultr

Washtenaw Area Transportation Study Dues

Washtenaw County CED -

Washtenaw County Mutual Aid

Washtenaw County Road Commission

Washtenaw County Treasurer

Washtenaw Urgent Care

Waste Management

Western Wayne County Mutual Aid

West Shore

Weingartz

Windstream

W.J. O'Neil

Wolff Networks, LLC

Wolverine Freightliner

YCUA

Ypsilanti Area Chamber of Commerce

Ypsilanti City DPW

Zoho Corp

Election Supplies

Tree Removal

Flash Cam Maintenance

Printer Services

Remote Screenshare

~~UPS Maintenance~~

Agreement with Washtenaw County for Senior Nutrition Program

Tires and MiDeal Items

Playscape Equipment for Specific Parks

Ball and Soccer Paint Supplies, Ice Melt

Only Michigan Toro Vendor

Fire Extinguisher Inspections/Maintenance

~~Systems Log Management~~

Engineers/Surveyors/Planners

Pagers

Life/Disability Insurance

Hydro Dam Maintenance

MiDeal

Chipper Engine Parts

Environmental Services

Fixed Assets Software

Employee Assistance Program (EPA)

Tree Service

Employer Portion of Fire Dept. OPEB

Systems Log Management

Mobile Phones

RecTrac Software Support

Concrete and Manhole Renovation

Server Virtualization Software

Vision Insurance

Website Hosting Services

Senior Nutrition Program

Purchase of Salt & Grading

Sheriff Services

Pre-employment Drug Screen/DOT Screens

Trash Haulers

Maintenance of Outdoor Sirens

STIHL Dealer (weed trimmers, chain saws, push mower)

Telephone Service

Mechanical

Structured Cable Installation Services

Chipper Trucks, Fire Engine Parts and Repair

Lift Stations, Vehicle and Equipment Repair

Road Salt

Network Monitoring/Request Racking Systems

OTHER BUSINESS

AUTHORIZATIONS AND BIDS

Supervisor
BRENDA L. STUMBO
Clerk
KAREN LOVEJOY ROE
Treasurer
LARRY J. DOE
Trustees
STAN ELDRIDGE
HEATHER ROE
MONICA ROSS-WILLIAMS
JIMMIE WILSON, JR.



Supervisor's Office

7200 S. Huron River Drive
Ypsilanti, MI 48197
Phone: (734) 481-0617
Fax: (734) 484-0002
www.ytown.org

TO: Karen Lovejoy Roe, Clerk
FROM: Brenda L. Stumbo, Supervisor *Dave*
DATE: November 29, 2016
RE: Request to formally authorize and accept sale of golf course equipment on the MITN Surplus Sale

Larry Doe, Javonna Neel, Tim Smith & Stan Eldridge met to discuss the sale of old equipment and the purchase of new. After meeting, it was agreed to proceed with the sale through the MITN online surplus sale.

We are requesting formal approval of the sale of items listed below:

1. 2012 Toro Groundsmaster 4100D 4 Wheel Drive Batwing	\$11,000.00
2. 2006 Toro Z-Master	2,500.00
3. 2000 Toro Workman 3200	1,225.00
4. 1990 Toro Sand Pro 14 w/blower	615.00
5. 2002 Toro Debris Blower 600	965.00

Total \$16,305.00

Please place this on the December 6, 2016 Board agenda under Authorizations & Bids.

If you have any questions, please contact Tim Smith.

tk

cc: Larry Doe
Javonna Neel
Tim Smith
Stan Eldridge